

# Policy Brief

Issue No.7, September 2015



## RE-DESIGN, FABRICATION AND PERFORMANCE EVALUATION OF MANUAL CONICAL DRUM SEEDER: A CASE STUDY

*R.M. Chandima Ratnayake and B.M.C.P. Balasoriya*

# Re-design, Fabrication and Performance Evaluation of Manual Conical Drum Seeder: A Case Study

\*R.M. Chandima Ratnayake<sup>1</sup> and B.M.C.P. Balasoriya<sup>2</sup>

<sup>1</sup>Associate Professor of Mechanical Engineering, Department of Mechanical and Structural Engineering  
 and Materials Science, Faculty of Science Technology, University of Stavanger,  
 N- 4036, Stavanger, Norway.

\*Corresponding author: [chandima.ratnayake@uis.no](mailto:chandima.ratnayake@uis.no)

<sup>2</sup> Deputy Director, Farm Mechanization Research Center (FMRC),  
 Department of Agriculture,  
 Maha-Illuppallama, Sri Lanka.

*Applied Engineering in Agriculture 29(2), 139-147. Copyright 2013 American Society of Agricultural and  
 Biological Engineers. Reprinted with Permission.*

**Abstract.** Rice cultivation is basically carried out by means of transplanting or direct sowing (DS). Although transplanting methods tend to give higher yields, the cost of operation is significantly high in relation to DS methods. Hence, to date, most farmers in the third world countries use manual broadcasting (MB) due to its economic viability. MB is direct sowing of pre-germinated paddy rice (DSPPR) by hand, based on personnel skill, on wet puddled soils. A major drawback of this method is that the distribution of pre-germinated paddy rice (PPR) is not uniform on the wet puddled soil, which results in a lower yield. Although the mechanization of DS has been achieved via manually operated mechanical drum seeders to overcome this challenge, these have their own inherent drawbacks. The present work was undertaken to re-design and develop a manually operated mechanical drum seeder, which can be used for sowing PPR, by taking into consideration currently available drum seeder designs and their drawbacks. The performance indicators for the new design were identified and evaluated. The performance of the new design in the paddy fields was evaluated in relation to MB by comparing the sown amounts and the resulting yield.

**Keywords:** manual broadcasting, direct sowing, conical drum seeder, pre-germinated paddy rice, mechanization, transplanting, yield, sown amount

## INTRODUCTION

Rice (*Oryza sativa*) provides an important essential food in conjunction with the general trend of diet diversification taking place around the world. It is one of the major cereal crops cultivated in more than 110 countries in the world with a total production of 527 million tonnes, of which 78 % is contributed by the major rice growing countries of Asia (Goel et al., 2008). For instance, rice is now the staple food of 2.7 billion people, almost half the world's population, and is cultivated by more than half the world's farmers (Fairhurst and Dobermann, 2002). India is the largest grower of rice in the world in terms of area: 44.97 million hectares with an annual production of 89.4 million tonnes at an average yield of 1990 kg/ha (Anonymous, 1999). However, it ranks second to China in terms of production. In a relatively small country like Sri Lanka, it is the main food as well as the single most important crop of the country, with rice cultivation occupying 34 % of the total cultivated land of the country and 1.8 million farmer families being engaged in rice cultivation (Department of Census and Statistics, 2006). Aside from that, rice consumption in Europe is growing with the general trend of diet diversification taking place throughout the continent (Minoiu, 2011). Hence, in order to cater for the increase in total rice consumption around the world, it is vital to increase production effectiveness and efficiency via effective reengineering and agricultural mechanization.

Rice is cultivated either by direct sowing (DS) or by transplanting. Direct sowing of rice (DSR) refers to the process of establishing a rice crop from seeds sown in the field rather than by transplanting seedlings from the nursery (Farooq et al., 2011). There are three approaches to DSR: dry seeding (sowing dry seeds into dry soil), wet seeding (sowing pre-germinated seeds on wet puddled soils, which is also called direct sowing of PPR

(DSPPR)) and water seeding (seeds sown into standing water). Manual transplanting of rice is a traditional method which gives a high and stable yield while being a time-consuming, laborious and expensive process (Johnkutty et al., 2002). For instance, manual transplanting of paddy requires about 250-300 man-hours per hectare (ha), which is 25 % of the total labor requirement of the crop (Chaudhary and Varshney, 2003). Further, in transplanting, usually fewer hills are planted per unit area (25-35 hill/m<sup>2</sup>) than recommended (50-60 hill/m<sup>2</sup>) to complete the planting quickly, resulting in reduced plant population and decreased yields. In such situations, direct seeding is helpful due to the lesser labor and time requirement, the low cost of cultivation due to the skipping of nursery raising and transplanting, the maintaining of the recommended plant population and also due to the early crop maturity by 7-12 days (Subbaiah et al., 2002; Gill, 2008). For instance, due to practicalities, if a delay of one month occurs in transplanting, then it reduces the yield by 25 %, whereas a delay of two months reduces the yield by 70 % (Rao and Pradhan, 1973). Hence, it is vital to replace the traditional transplanting of rice (TPR) with other alternatives such as improved direct-sowing (DS) methods, as to date use of the manual labor is quite demanding.

DS methods have several advantages over transplanting (Singh et al., 2005a). In addition to higher economic returns, DSR crops are faster and easier to plant, less labor intensive, consume less water (Bhushan et al., 2007; Jehangir et al., 2005), are conducive to mechanization (Khade et al., 1993), generally flower earlier leading to shorter crop duration (Farooq et al., 2006a,b; Santhi et al., 1998), mature 7-10 days earlier, and produce fewer methane emissions (Balasubramanian and Hill, 2002; Pandey and Velasco, 1999) than TPR. Typically, DSR is established earlier than TPR without growth delays from transplant injury; this hastens physiological maturity and reduces vulnerability to late-season drought (Tuong et al., 2000). DS also offers the option to resolve edaphic conflicts (between rice and the subsequent non-rice crops) and to enhance the sustainability of both the rice-wheat cropping system and the succeeding winter crops, particularly early sown wheat (Ladha et al., 2003; Singh et al., 2005a,b). The yield in DSR is often lower than in TPR, principally owing to poor crop stand and high weed infestation (Singh et al., 2005a). Moreover, the cost of weed control is usually higher than in TPR. High weed infestation is a major constraint for broader adoption of DSR (Rao et al., 2007). Likewise, micronutrient deficiencies such as Zn and Fe, due to imbalanced N fertilization and high infiltration rates in DSR, are of major concern (Gao et al., 2006; Saleque and Kirk, 1995). However, owing to water and labor shortages (Pandey and Velasco, 1999) and soil degradation under intensive TPR (Sinha et al., 1998), farmers are inclining to the adoption of DSR. Also, some researchers revealed that the DS of PPR seeds using a drum seeder has resulted in lower production costs and higher yield, as compared to manual transplanting (Devnani, 2002b; Subbaiah et al., 2002; Tajuddin and Rajendran, 2002; Johnkutty et al., 2002). The area under DSR is increasing as its greater productivity and profitability compensates for the production costs.

The maximum return per surface area in rice cultivation depends on the establishment of a plant population with recommended spacing (Kepner et al., 1982; Chaudhury et al., 2005). Hence, optimization of the density of the rice plants plays a major role in terms of seed metering and distribution. The purpose of seed metering is accurate and uniform seeding (Jorgenson, 1988) that causes no damage to the seed (see Soza et al., 2004). The seed distribution refers to the planting of seeds according to a predetermined pattern (see Soza et al., 2004). Also, it is vital to have plant-to-plant and row-to-row uniform spacing to utilize mechanical weeding. Currently, the manual broadcasting (MB) method (i.e. also called manual throwing rice seedling) is widely used for rice cultivation due to its economic viability. For instance, in the Orissa province, MB has been used in about 2.24 million hectares, whilst transplanting has only been used in about 1.64 million hectares. The reasons for the increased use of MB are mainly: the socio-economic condition of the people, the non-availability of labor in peak transplanting seasons and the non-availability of suitable transplanting machines. However, with BM it is not possible to optimize plant density, which is considered to be essential for optimizing paddy yield (Chaudhury et al., 2005). On the other hand, dropping seeds at an equal interval and in an almost uniform number has the potential to further reduce the seed requirement per hectare, whilst achieving uniformly spaced planting similar to TPR, providing enough space to grow and enhance the yield (Aldas and Sakurai, 2001). Alternatively, Hongguang and Wentao (2010) suggested that mechanized sowing is the most important DS approach to achieve the target of high yield, high efficiency and high quality, and promote agricultural production, while reducing investment and increasing benefits. Also, several researchers reported the possibility of higher net returns from using improved DS methods compared to manual broadcasting (Farooq et al., 2011; Sharma and Singh, 2004; Gill, 2008; Gangwar et al., 2008). Hence, it is vital to develop a mechanized DSR method that is affordable to farmers.

Although the mechanization of DSPPR via drum seeders has been introduced by various institutes and personnel over the past decades, they have their own trade-offs (e.g. irregular seed distribution, size, cost, etc.) between inherent advantages and disadvantages. As the advantages of mechanized DS are still not recognized and transplanting is inherently expensive, farmers tend to use less efficient, although economically viable, MB. Hence, the present work was undertaken to re-design and develop a manual drum seeder which can be used for sowing PPR by taking into consideration currently available manual drum seeder designs and their drawbacks.

The performance of the new design was evaluated in relation to MB by comparing the sown amounts and the resulting yield.

## DRAWBACKS PRESENT IN CURRENTLY AVAILABLE MECHANICAL DRUM SEEDERS

A mechanical seeder generally has two basic functions: first, metering of the seeds from a bulk supply; second, conveying and placing the metered seeds at a desirable location in the soil. However, there is a tendency for pre-germinated seeds to interlock with each other in mechanical seeders which increases bridging in the hopper (Navasero, 1969). Although agitators are used to reduce bridging, they cause mechanical damage to pre-germinated seeds. Hence, Navasero (1969) suggested using a two-step metering device to avoid bridging. Devanani (2002a) has reported that direct seeding of PPR seeds using a drum seeder (i.e. also called pre-germinated paddy seeder) is the most common method for sowing paddy rice in medium and small farms. This method provides additional advantages such as no nursery rising and transplanting required (Mathankar and Singh, 2007). Although various types of drum seeders were produced by individuals and institutes, all these seeders have several features that are common. They consist of several cylindrical shaped drums to contain seed, and these drums are rotated by an axle connected to one or two wheels. There is also a handle to pull the seeder. The seeds are dropped from the openings at the circumference of both sides of the drums (see Figure 1 and Figure 2).

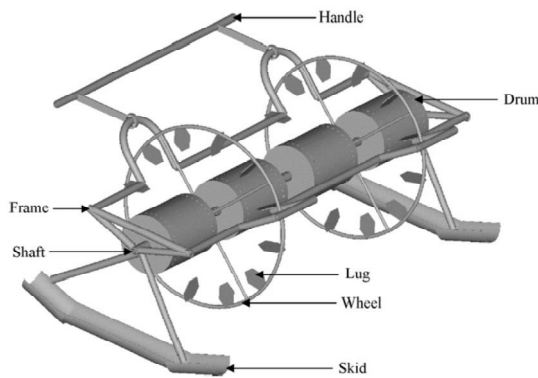

Figure 1. An eight row manual drum seeder.



Figure 2. A sixteen row manual drum seeder.

The seed drills (i.e. a sowing device that positions seeds in the soil) in the currently available seeder models (as a drum) seed at a non-uniform rate. Besides being wasteful, this causes planting to become imprecise, leading to a poor distribution of seeds (i.e. seed-to-seed spacing along a line) and low productivity. For instance, Prasanna Kumar et al. (2004) observed that the flow rate of paddy rice seeds through the orifices on the circumference of the drum is not uniform during operation, leading to variation in seed spacing and seed rate. Moreover, Sivakumar et al. (2003) and Sivakumar et al. (2005) observed a non-linear increase in seed rate as the seeder drum becomes empty. In general, factors such as: orifice size, spacing between the orifices on the drum, percentage fill of drum, and speed of operation significantly affected the flow rate of seeds through the orifices (Prasanna Kumar et al., 2004). Caponeri et al. (1995) reported that, when the drum was half-full and rotated at low speeds, the seeds fell intermittently in avalanches down the inclined surface with the majority of the seeds in solid-body rotation with the rough drum. At intermediate speeds, there was a continuous motion of seeds falling down the inclined surface with some quasi-static motion in the interior. At very high speeds, the seeds were thrown by centrifugal forces on to the outside and there was very little relative motion. Some researchers reported that the flow of seeds varies irregularly with time at speeds lower than a certain threshold (Rajchenbach, 2000; Poschel and Buchholtz, 1995). In general, with almost all of the mechanical drum seeders, seeding suffers from the irregular seed spacing and seed rate as well as the lack of proper mechanism to control seed rate according to size/variety of the paddy seeds (e.g. Samba, Nadu varieties, etc. have different seed sizes). Also, they are difficult to use in small plots because of their geometry. Therefore, the present work was undertaken with the objectives mentioned in the next section.

## OBJECTIVE

To design a mechanical drum seeder for DS of pre-germinated paddy and evaluate its performance in relation to MB. The drum seeder should be able to: operate with minimum operator skill and effort, control seed rate according to size/variety of paddy seeds, establish a uniform plant population in a paddy field, and be suitable

for use in small and medium size plots; it should also be light enough in weight for one man operation, locally manufactured, simple and low cost.

## MATERIALS AND METHODS

The criteria for seeder design were concluded to overcome the challenges pertaining to currently available pre-germinated paddy drum seeder models. The set of criteria include the possibility to maintain a uniform seed rate and light weight, direct PPR seeds using a drum seeder on hills with spacing (20 cm × 10 cm), float in boggy fields, be manufactured locally, be simple and low cost, and be suitable for use in small and medium-size plots with minimum operator skill and effort.

### METHODOLOGY FOR DESIGNING OF CONICAL DRUM SEEDER

In order to achieve uniform flow rate with the decrease in the percentage fill of the drum, the conventional cylindrical shape of the drum is changed to conical shape geometry. The geometry of the conical shape was derived using the trial and error methods based on the experience gained from other currently available seeders geometries. The conical shape geometry allows grains to flow to the bottom-most position of the drum via gravity, which is not the case in the cylindrical shaped drum. Also, in order to maintain uniform seed spacing and seed rate, tubes were introduced to each hole around the circumference of the drum. This allows the required delay to meet uniform seed spacing as the grains are passing through the tube (i.e. after flowing out from the drum) (see Figures 3 and 4). Inside the drum, agitators were fixed to control the flow against the possible centrifugal flow of seeds. A floater was designed and attached in order to float in boggy conditions. A sheet metal of gauge 18 was used to fabricate the drum and skid/floater.



Figure 3. Initial design of conical drum seeder.

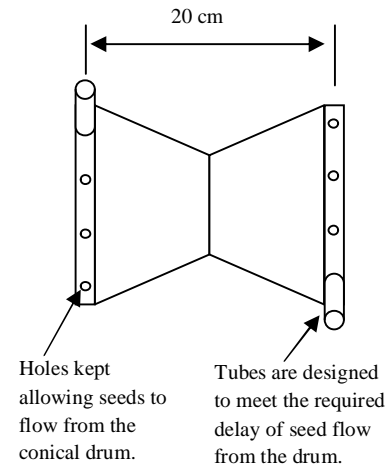
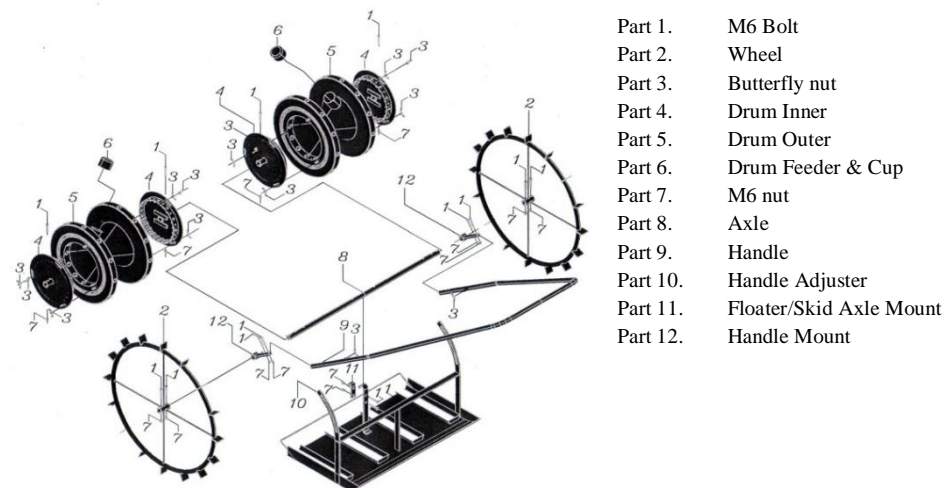

Figure 4. Conical shape drum.

The initial design had three drums forming six rows at once (see Figure 3). Drums were fixed to an axel (Part 8 of Figure 5), which was connected to two wheels (Part 2. of Figure 5) having lugs to facilitate rotating even in boggy fields. A skid (Part 13 of Figure 5) is attached to the frame for floating in boggy conditions. The skid was designed with open furrows to be able to position seeds in the soil (see Figure 5). Two rows of orifices are provided on the circumference of each conical shaped drum in order to obtain the recommended spacing of 20 mm (see Figure 4) between the rows and 15 mm between the hills (Nwilene et al., 2008). Drums are rigidly fitted on the axel 20 cm apart. Wheels of about 60 cm diameter are connected to the axel such that when the wheels rotate, drums rotate along with shaft and wheels, placing 12 hills in 6 rows per revolution. The handle (Part 9. of Figure 5) is connected to the axel by nylon/steel bushes. The skid is supported by the frame and hinged to the axel so that the operator can adjust the angle according to his height and field condition.

After carrying out about 25 trails with the conical drum seeder (CDS) illustrated in Figure 3, it was found that there was no proper mechanism to control the seed rate according to the variety of the seed. For instance, if the size of the holes (see Figure 4) along the circumference of the conical drum is designed for a variety of rice having long grain (e.g. 12 mm for Nadu), an excessive amount of short grain rice (e.g. Samba) was delivered without control. On the other hand, if the hole size is kept for a variety of rice having shorter grain size (e.g. 8 mm for Samba), then a longer grain rice variety (e.g. Nadu) will not drop at all. Hence, a mechanism is designed to control the size of the hole according to the grain size of the rice variety. Apart from that, it was also revealed that the weight of the machine is excessive (25 kg without seeds), it is difficult to turn the seeder at the end of the plot (it needed the support of another person), and the drums & floater/skid might get corroded easily as it is generally supposed to be used in mud.

Hence, in order to improve the performance of the seeder, some changes were made. The number of conical drums was reduced to two to reduce weight and facilitate turning at the end of the plot. Also, in the new design, an inner drum was introduced concentrically to the outer drum (Part 4 and Part 5 in Figure 5). Then, 8 mm and 12 mm holes were introduced one after the other along the circumference of the inner drum, whilst only 12 mm holes were introduced along the circumference of the outer drum. The outer drum was designed to be able to rotate relative to the inner. When the 12 mm hole of the outer drum coincides with the inner 12 mm hole, the seeder is set to longer grain (e.g. Nadu) varieties. However, when the 8 mm hole of the inner drum coincides with the 12 mm hole of the outer, the seeder is set for shorter grain (e.g. Samba) varieties. Furthermore, it is possible to adjust the seed rate by offsetting the two holes by trial and error. In order to reduce the weight and prevent corrosion, both the drums and the skid/floater were fabricated with fiberglass. Although the ideal material is plastic, the utilization of it was avoided due to the high cost of molding. Figure 5 illustrates the improved design of the CDS and its parts.



- Part 1. M6 Bolt
- Part 2. Wheel
- Part 3. Butterfly nut
- Part 4. Drum Inner
- Part 5. Drum Outer
- Part 6. Drum Feeder & Cup
- Part 7. M6 nut
- Part 8. Axle
- Part 9. Handle
- Part 10. Handle Adjuster
- Part 11. Floater/Skid Axle Mount
- Part 12. Handle Mount

Figure 5. Improved design: part list of the adjustable conical drum seeder.

Figures 6 and 7 illustrate the prototype of the improved design of the SDS.

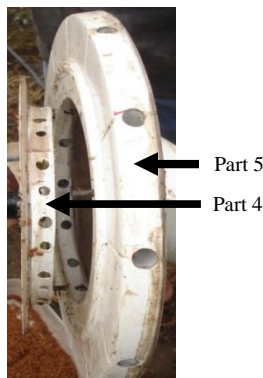

Figure 6. Adjustable drum.



Figure 7. Adjustable conical shape drum seeder.

**METHODOLOGY FOR FIELD PREPARATION, SEED PREPARATION AND CONICAL DRUM SEEDER APPLICATION**

The initial field preparation for the seeder was same as the conventional methods employed for manual broadcasting or transplanting. For instance, after the second or third tillage (i.e. the agricultural preparation of the soil by mechanical agitation of various types, such as digging, stirring, and overturning), the field was properly puddled (i.e. allowing a small accumulation of water on the surface). Then, a day before seeding, excess water was cut off and the corresponding field was properly leveled. A couple of channels were arranged appropriately perpendicular to the CDS moving direction (see Figure 3).

In order to prepare the paddy rice seeds, they were soaked in water for nearly 36 hours. After that they were drained and incubated for 24 hours to become pre-germinated. The PPR seeds were used for direct seeding

using the CDS when the sprouts were just emerging from them. The aforementioned timing is paramount, as if the pre-germinated paddy seeds are incubated for more than 24 hours, then the emerging roots get entangled inside the drum and prevent seeds flowing out from the CDS.

Once the PPR seeds were prepared, the conical drum feeders were filled to the two thirds level with them and pulled along the field, as indicated in Figure 3. In order to reduce the number of turnings, the CDS were pulled lengthwise along the paddy field. The floaters/skids were adjusted according to the height of the operator as well as the field condition.

**METHODOLOGY FOR PERFORMANCE EVALUATION OF CONICAL DRUM SEEDER**

The key performance indicators were recognized as illustrated in Table 1 for evaluating the performance of the CDS (Lacayanga et al., 2009).

**Table 1. Performance indicators of conical drum seeder.**

Performance indicator	Notation
Theoretical Field Capacity	<i>C</i>
Effective Field Capacity	<i>EFC</i>
Field Efficiency	<i>FE</i>
Seeding Rate	<i>S<sub>r</sub></i>
Missing Hills	<i>M<sub>h</sub></i>
Wheel Slippage	<i>S<sub>w</sub></i>

$$C = \frac{W \cdot S}{10} \dots \dots \dots (1)$$

where, *C*: Theoretical field capacity; ha/hr (Note: 1 ha = 0.01 km<sup>2</sup>)  
*S*: Forward speed, km/hr  
*W*: Width of cut of the device, m

The EFC includes the time lost during the actual field operation such as time lost due to turning, loading, adjustment and other time losses during the operation.

$$EFC = \frac{A}{T} \dots \dots \dots (2)$$

where, *EFC*: Effective field capacity, ha/hr  
*A*: Area, ha  
*T*: Time to finish the area, hr

$$FE = \frac{EFC}{C} \cdot 100 \dots \dots \dots (3)$$

$$S_r = \frac{W_{seeds}}{A} \cdot 100 \dots \dots \dots (4)$$

where, *W<sub>seeds</sub>*: Weight of seeds consumed, kg  
*A*: Area, ha

$$M_h = \frac{H_T - H_A}{H_T} \cdot 100 \dots \dots \dots (5)$$

where, *H<sub>T</sub>*: Theoretical number of hills to be seeded  
*H<sub>A</sub>*: Actual number of hills to be seeded

$$S_w = \frac{D_w \cdot N - L}{D_w \cdot N} \cdot 100 \dots \dots \dots (6)$$

where, *D<sub>w</sub>*: Diameter of the wheel  
*N*: Number of revolutions travelled  
*L*: Actual distance travelled in N revolutions

## PERFORMANCE ANALYSIS OF CONICAL DRUM SEEDER

Effective field capacity is calculated assuming that an average farmer works eight hours a day continuously, which may not always be the case. In actual practice, a farmer's travelling speed can decrease with time due to the fact that it is hard labor and also because there are other time expenditures such as lunch breaks and rests. Hence, in reality, the EFC value will be much lower if a single person operates the conical drum seeder. It is also noted that the EFC value is almost the same as in manual seed broadcasting. The seed rate is approximately 25 kg/ha. However, in conventional manual broadcasting, a farmer uses nearly 101 kg/ha. Therefore, by utilizing a mechanized approach with a conical drum seeder, about 75% of paddy seed is saved. There is no wheel slippage due to skidding, as the machine tends to float in boggy conditions (see Ratnayake and Balasooriya, 2011). Table 2 illustrates the values of the conical drum seeder's performance.

**Table 2. Conical drum seeder performance.**

Performance indicator	Value
Theoretical Field Capacity	0.22 ha/h
Effective Field Capacity	0.18 ha/h
Field Efficiency	81%
Seeding Rate	25 kg/ha
Missing Hills	3.70%
Wheel Slippage	-1.50%
Average Row Distance	19.3 cm
Average Hill Distance	13.4 cm

## COMPARISON OF DATA COLLECTED FOR SOWN VS. YIELD AMOUNTS

Two seasons and 13 different locations in the case study country were selected to reduce the bias in making a yield comparison between DSPPR using a conical drum seeder (CDS) and DSPPR using manual broadcasting (MB). The experiment was carried out over the period from 2008 to 2010. Table 3 illustrates the comparison of sown and yield quantities using a conical drum seeder and manual broadcasting.

**Table 3. Comparison of sown and yield quantities using conical drum seeder and manual broadcasting.**

Experiment	Season	Location	Average quantity				% difference with respect to MB quantity			
			Using CDS		Using MB		Difference (DS-MB)			
			Sown <sup>DS</sup> (PPR, kg/ha)	Yield <sup>DS</sup> (Paddy seeds, kg/ha)	Sown <sup>MB</sup> (PPR, kg/ha)	Yield <sup>MB</sup> (Paddy seeds, kg/ha)	Sown <sup>(DS-MB)</sup> (PPR, kg/ha)	Yield <sup>(DS-MB)</sup> (Paddy seeds, kg/ha)	Sown (PPR, %)	Yield (Paddy seeds, %)
1	1	1	39.68	6 804.60	152.52	6031.35	-112.84	773.25	-73.98	12.82
2	1	2	39.20	6 082.90	127.10	4124.00	-87.90	1 958.90	-69.16	47.50
3	2	3	31.80	7 010.80	101.68	5515.85	-69.88	1 494.95	-68.73	27.10
4	2	4	32.00	7 732.50	101.68	6082.90	-69.68	1 649.60	-68.53	27.12
5	2	5	34.65	8 196.45	101.68	5051.90	-67.03	3 144.55	-65.92	62.24
6	2	6	33.40	7 990.25	127.00	5000.35	-93.60	2 989.90	-73.70	59.79
7	2	6	31.20	9 691.40	101.68	6804.60	-70.48	2 886.80	-69.32	42.42
8	2	7	28.00	9 691.40	101.00	6804.60	-73.00	2 886.80	-72.28	42.42
9	2	2	34.72	9 691.40	101.60	6804.60	-66.88	2 886.80	-65.83	42.42
10	2	8	25.42	7 113.90	127.00	4639.50	-101.58	2 474.40	-79.98	53.33
11	2	9	26.04	5 335.43	115.00	4691.05	-88.96	644.37	-77.36	13.74
12	2	10	23.80	6 804.60	101.68	5114.28	-77.88	1 690.32	-76.59	33.05
13	2	11	27.28	8 016.03	140.00	5077.68	-112.72	2 938.35	-80.51	57.87
14	2	12	22.32	7 784.05	127.00	6031.35	-104.68	1 752.70	-82.43	29.06
15	2	13	22.00	5 361.20	128.00	5000.35	-106.00	360.85	-82.81	7.22

## RESULTS AND DISCUSSION

Figure 8 illustrates the distribution of sown PPR quantities using CDS and MB in 15 experiments which were carried out in 13 different locations.



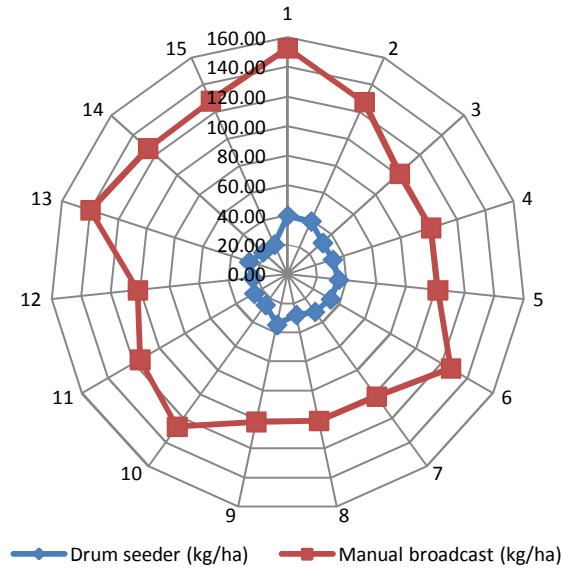

Figure 8. Distribution of sown PPR quantities using CDS and MB.

Figure 8 revealed that sown quantities used for MB are significantly higher than the sown quantities used with the CDS. Figure 9 illustrates a comparison of yield quantities when the PPR has been sown with CDS and MB.

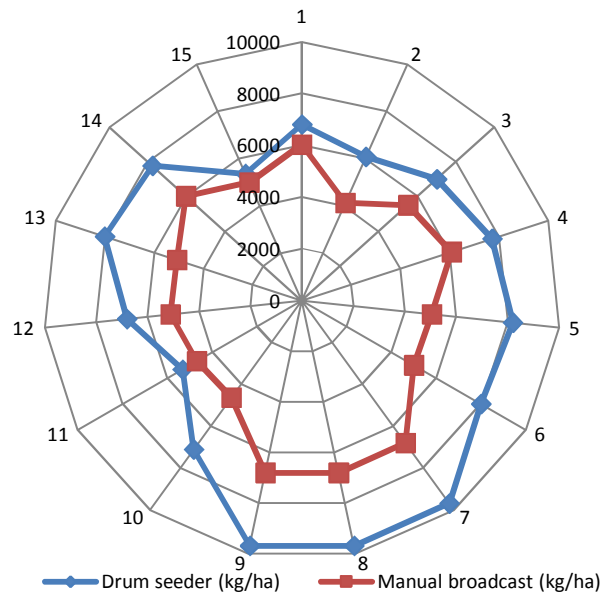

Figure 9. Distribution of yield quantities using CDS and MB.

Figure 9 revealed that the resulting yield when the PPR seeds have been sown with the CDS is significantly higher than the MB of the PPR in almost all the experiments, except experiments 1, 11 and 15 (see Figure 9). In addition to the DS method, other factors also affect the yield. For instance, factors like farm management practices; application of fertilizer and its quantities; weed management methods; weather conditions, etc. affect the final yield. In all experiments, it is clearly noticeable that at least 10 % in yield increase is anticipated if CDS is used as the sowing method. For instance, Table 4 revealed that the average consumption percentage of PPR using the CDS is less than 75% (i.e. 73.81%) that of MB.

Table 4. Summary of sown and yield data for conical drum seeder and manual broadcasting.

	Average (kg/ha)			
	Amount of seeds		Difference (DS-MB)	% difference with respect to MB
	CDS	MB		
Sown	30.10	116.97	-86.87	-73.81
Yield	7 553.79	5518.29	2 035.50	37.21

Table 4 also reveals that on average there is a 37.21% increase in yield using CDS compared to MB. Hence, it can be concluded that, using a CDS, it is possible to achieve significant savings in sown quantities and a gain in yield.

## CONCLUSION

DS via a manually operated CDS discussed in this manuscript is capable of placing seeds in four rows, whilst providing simple and easy operation for an average person. To achieve uniformity and flexibility in operations, different mechanisms have been introduced. This allows uniformly spaced planting, similar to the case for the transplanted rice, providing space for growth and offering a higher yield in return. In general, mechanized DS reduces the labor needed by 20% (Sivakumar et al., 2003). The use of the DS method further increases the return on investment, as it eliminates the cost of excessive seeds and labor for pulling and transplanting; the reduced stress caused by pulling results in a much higher percentage of germination and survival rate. Hence, the DS technique using the CDS design suggested in this manuscript provides more effective and efficient rice production. Also, if the cost of labor is high and the availability is less, then the suggested method in this manuscript provides an alternative for transplanting and MB. The suggested improved CDS design further reduces the amount of PPR seed required to sow per hectare (see the sown amounts using CDS in experiments 10-15 in Table 3), as it makes it possible to drop PPR at an equal interval and in an almost uniform number.

Future research should be carried out in order to make a comparison of the different designs available for the DS (i.e. cylindrical drum seeder, conical drum seeder, etc.) in relation to sown pre-germinated and yield paddy rice amounts. Also, a study should be performed to carry out a cost benefit analysis of the different types of DS methods used in rice cultivation.

## REFERENCES

- Aldas, R. E., and H. Sakurai. 2001. Study on two row manual rice seeder with plunger type mechanism for hill seeding rice. *The Philippine Society of Agricultural Engineers Journal*: 13-18.
- Anonymous. 1999. *Food & Agric Organization of the United Nations*. FAO Year Book. 53, Rome, Italy.
- Balasubramanian, V., and J. E. Hill. 2002. Direct seeding of rice in Asia: emerging issues and strategic research needs for the 21st century. In *Direct Seeding: Research Strategies and Opportunities*, 15-42. S. Pandey, M. Mortimer, L. Wade, T. P. Tuong, K. Lopez, and B. Hardy, eds. Los Ban'os, Philippines: Inter. Rice Res. Inst.
- Bhushan, L., J. K. Ladha, R. K. Gupta, S. Singh, A. Tirol-Padre, Y. S. Saharawat, M. Gathala, and H. Pathak. 2007. Saving of water and labor in a rice-wheat system with no-tillage and direct seeding technologies. *Agron. J.* 99: 1288-1296.
- Caponeri, M., S. Douady, S. Fauve, and C. Laroche. 1995. Dynamics of avalanches in a rotating cylinder. In *Mobile Particulate Systems, Nato Asi Series E*, 331-336. E. Guazzelli, and L. Oger, eds. The Netherlands: Nato Kluwer Academic Publishers.
- Chaudhary, V. P., and B. P. Varshney. 2003. Performance evaluation of self-propelled rice transplanter under different puddle field conditions and sedimentation periods. *Agril. Mech. Asia, Africa, Latin America*. 34: 23-33.
- Chaudhury, V. P., B. P. Varshney, and S. K. Singh. 2005. Self-propelled rice transplanter – a better alternative than manual transplanting. *Agricultural Engineering Today*. 29(5-6): 32-37.
- Department of Census and Statistics. 2006. *Annual Report*. Colombo, Sri Lanka: Department of Census and Statistics.
- Devnanai, R. S. 2002a. Technology for pre-germinated paddy seeding. *J. Agric. Eng.* 39(2): 1-8.
- Devnani, R. S. 2002b. Direct seeding options, equipment developed and their performance on yield of rice crop. *Agric. Mech. Asia, Africa, Latin America*. 33(4): 27-33.
- Fairhurst, T. H., and A. Dobermann. 2002. Rice in the global food supply. *Better Crops International*. 16: Special Supplement, May.
- Farooq, M., S. M. A. Basra, R. Tabassum, and I. Afzal. 2006b. Enhancing the performance of direct seeded fine rice by seed priming. *Plant Prod. Sci.* 9: 446-456.

- Farooq, M., S. M. A. Basra, and A. Wahid. 2006a. Priming of field-sown rice seed enhances germination, seedling establishment, allometry and yield. *Plant Growth Regul.* 49: 285-294.
- Farooq, M., K. H. M. Siddique, H. Rehman, T. Aziz, D. J. Lee, and A. Wahid. 2011. Rice direct seeding: experiences, challenges and opportunities. *Soil & Tillage Research.* 111(2): 87-98.
- Gangwar, K. S., O. K. Tomar, and D. K. Pandey. 2008. Productivity and economics of transplanted and direct-seeded rice (*Oryza sativa*) -based cropping systems in Indo-Gangetic plains. *Indian J. Agric. Sci.* 78: 655-658.
- Gao, X. P., C. Q. Zou, X. Y. Fan, F. S. Zhang, and E. Hoffland. 2006. From flooded to aerobic conditions in rice cultivation: consequences for zinc uptake. *Plant Soil.* 280: 41-47.
- Gill, M. S. 2008. Productivity of direct-seeded rice (*Oryza sativa*) under varying seed rates, weed control and irrigation levels. *Indian J. Agric. Sci.* 78: 766-770.
- Goel, A. K., D. Behera, and S. Swain. 2008. Effect of sedimentation period on performance of rice transplanter. *Agricultural Engineering International: the CIGR Ejournal.* Manuscript PM 07034. X. Available at: [www.cigrjournal.org/index.php/Ejournal/article/view/1017/1010](http://www.cigrjournal.org/index.php/Ejournal/article/view/1017/1010). Accessed 6 August 2011.
- Hongguang, C. U. I., and R. E. N. Wentao. 2010. Field experiment on taped seed rice planting technology. Available at: <http://www.seiofbluemountain.com/upload/product/201010/2010dthy02a3.pdf>. Accessed 11 June 2012.
- Jehangir, W. A., I. Masih, S. Ahmed, M. A. Gill, M. Ahmad, R. A. Mann, M. R. Chaudhary, and H. Turrall. 2005. Sustaining crop water productivity in rice-wheat systems of South Asia: a case study from Punjab Pakistan. In Draft Working Paper. Lahore, Pakistan: Inter. Water Managmt. Institute.
- Johnkutty, I., G. Mathew, and J. Mathew. 2002. Comparison between transplanting and direct seeding methods for crop establishment in rice. *Journal of Tropical Agriculture.* 40: 65-66.
- Jorgenson, M. 1988. *International seed testing association.* 21 supplement, Zurich, Swiss: 228.
- Kepner, R. A., R. Bainer, and E. L. Barger. 1982. *Principles of Farm Machinery.* 3rd ed. 527. Westport, Connecticut: AVI Publishing Company, Inc.
- Khade, V. N., B. D. Patil, S. A. Khanvilkar, and L. S. Chavan. 1993. Effect of seeding rates and level of N on yield of direct-seeded (Rahu) summer rice in Konkan. *J. Maharashtra. Agric. Univ.* 18: 32-35.
- Lacayanga, J. E., W. G. Valdez, R. L. Ines, and R. P. Calderon. 2009. Improved manual rice hill seeder for wetland paddy. *LUMINA An Interdisciplinary Research and Scholarly Journal.* 20(1): March.
- Ladha, J. K., H. Pathak, A. T. Padre, D. Dawe, and R. K. Gupta. 2003. Productivity trends in intensive rice-wheat cropping systems in Asia. In *Improving the Productivity and Sustainability of Rice-Wheat Systems: Issues and Impacts.* JASA Special Publication No. 65. 45-76. K. Ladha, J. E. Hill, R. J. Buresh, J. Duxbury, and R. K. Gupta, eds. Madison, WI: ASA, CSSA, and SSSA.
- Mathankar, S. K., and V. V. Singh. 2007. Ridge seeding of pre-germinated rice in puddle fields. ASAE Paper No. 078042. St. Joseph, MI: ASABE.
- Minoiu, D. 2011. EEC rice producers' prospects facing rapidly changing EU rice-market characteristics and increased world competition. *Cahiers Options Méditerranéennes.* 50: 41-43. Available at: <http://ressources.ciheam.org/om/pdf/c50/03400003.pdf>. Accessed 4 August 2011.
- Navasero, N. C. 1969. A row seeder for lowland rice soils, Bibliographic Input Sheet, Agency for International Development. Available at: [http://pdf.usaid.gov/pdf\\_docs/PNRAB560.pdf](http://pdf.usaid.gov/pdf_docs/PNRAB560.pdf). Accessed 25 May 2012.
- Nwilene, F. E., S. O. Oikeh, T. A. Agunbiade, O. Oladimeji, O. Ajayi, M. Sié, G. B. Gregorio, A. Togola, and A. D. Touré. 2008. Growing lowland rice: a production handbook, Africa Rice Center (WARDA): 12. Available at: [http://www.fao.org/fileadmin/user\\_upload/ivc/docs/Growing%20lowland%20rice\\_%20production%20handbook\\_prepress%20final%20version\\_19-05-08\\_low%20res.pdf](http://www.fao.org/fileadmin/user_upload/ivc/docs/Growing%20lowland%20rice_%20production%20handbook_prepress%20final%20version_19-05-08_low%20res.pdf). Accessed 29 September 2011.

- Pandey, S., and L. E. Velasco. 1999. Economics of alternative rice establishment methods in Asia: a strategic analysis. In Social Sciences Division Discussion Paper. Los Bano's, Philippines: International Rice Research Institute.
- Poschel, T., and V. Buchholtz. 1995. Complex flow of granular material in a rotating cylinder. *Chaos, Solitons Fract.* 5(10): 1901-1912.
- Prasanna Kumar, G. V., R. Jhonhas, and V. Obed Natso. 2004. Flow rate of paddy seeds through sharp-edged orifices on the rotating drum of drum seeder. In *Proc. International Conf. on Emerging Trends in Agricultural Engineering (ETAET'04)*, 9-15. Kharagpur, India: IIT.
- Rajchenbach, J. 2000. Granular flows. *Adv. Phys.* 49(2): 229-256.
- Ratnayake, R. M. C., and B. M. C. P. Balasooriya. 2011. Sustainable rice production: a case study on performance evaluation of a seeder. *Management and Production Engineering Review*. ISSN 2082-1344, 2(4): 50-56.
- Rao, A. N., D. E. Johnson, B. Sivaprasad, J. K. Ladha, and A. M. Mortimer. 2007. Weed management in direct-seeded rice. *Adv. Agron.* 93: 153-255.
- Rao, M. V., and S. N. Pradhan. 1973. Cultivation practices. Rice Production Manual, 71-95. ICAR.
- Saleque, M. A., and G. J. D. Kirk. 1995. Root induced solubilization of phosphate in the rhizosphere of lowland rice. *New Phytol.* 129: 325-336.
- Santhi, P., K. Ponnuswamy, and N. K. Cheety. 1998. Effect of seeding methods and efficient nitrogen management practices on the growth of lowland rice. *J. Ecobiol.* 10: 123-132.
- Sharma, S. C., and T. P. Singh. 2004. Pantnagar developed mat type nursery raising device for rice transplanter. *Agricultural Engineering Today*. 28(1-2): 70-71.
- Singh, S., L. Bhushan, and S. K. Ladha. 2005b. Evaluation of new crop establishment / tillage techniques in rice-wheat system. In Agenda Notes, *13th Regional Technical Coordination Committee Meeting*, 6-8 February 2004, Rice-wheat Consortium for the Indo-Gangetic Plains, 12-13. Dhaka, Bangladesh.
- Singh, Y., G. Singh, D. Johnson, and M. Mortimer. 2005a. Changing from transplanted rice to direct seeding in the rice-wheat cropping system in India. In *Rice is Life: Scientific Perspectives for the 21st Century*, Tsukuba, Japan: *Proc. World Rice Research Conf.*, 4-7 November 2004: 198-201.
- Sinha, S. K., G. B. Singh, and R. Manga. 1998. Decline in crop productivity in Haryana and Punjab ó myth or reality. Report of the Fact-finding Committee, New Delhi: ICAR.
- Sivakumar, S. S., R. Manian, and K. Kathirvel. 2003. An improved direct-rice seeder, *International Rice Research Notes*. 28(2): 53-54.
- Sivakumar, S. S., R. Manian, K. Kathirvel, and G. S. V. Raghavan. 2005. Investigation on the influence of machine and operational parameters for the development of a manually drawn rice seeder for direct sowing. *Agric. Eng. Int. CIGR E-J.* 7: 1-12.
- Soza, E., G. Botta, M. Tourn, and R. Hidalgo. 2004. Sowing efficiency of two seeding machines with different metering devices and distribution systems: a comparison using soybean *Glycine max (L) Merr.* *Spanish Journal of Agricultural Research*. 2(3): 315-321.
- Subbaiah, S. V., V. Balasubramanian, and K. Krishnaiah. 2002. Evaluation of drum seeder in puddle rice fields. *Agric. Mech. Asia, Africa, Latin America*. 33(4): 23-26.
- Tajuddin, A., and P. Rajendran. 2002. Devices for inter-cropping green manure in wet seeded rice. *Agric. Mech. Asia, Africa, Latin America*. 33(3): 9-10.
- Tuong, T. P., P. P. Pablico, M. Yamauchi, R. Confesor, and K. Moody. 2000. Increasing water productivity and weed suppression of wet seeded rice: effect of water management and rice genotypes. *J. Exp. Agric.* 36: 1-19.



*Towards a more resilient, inclusive  
and sustainable Asia and the Pacific*

CSAM, Centre for Sustainable Agricultural Mechanization, is a regional institution of the United Nations Economic and Social Commission for Asia and the Pacific (UNESCAP), based in Beijing, China. CSAM started operations in 2004, built on the achievements of the Regional Network for Agricultural Machinery (RNAM) established in 1977 with support of UNDP, FAO and UNIDO, and the United Nations Asian and Pacific Centre for Agricultural Engineering and Machinery (UNAPCAEM). CSAM serves the 62 members and associate members of UNESCAP.

The vision of CSAM is to achieve production gains, improved rural livelihood and poverty alleviation through sustainable agricultural mechanization for a more resilient, inclusive and sustainable Asia and the Pacific.

CSAM's objectives are to enhance technical cooperation among the members and associate members of UNESCAP as well as other interested member States of the United Nations, through extensive exchange of information and sharing of knowledge, and promotion of research and development and agro-business development in the area of sustainable agricultural mechanization and technology transfer for the attainment of the internationally agreed development goals including the Millennium Development Goals in the Asia-Pacific region.

#### Disclaimer

The designations used and the presentation of the material in this publication do not imply the express opinion on the part of the ESCAP Secretariat concerning the delimitation of its frontiers or boundaries. The views expressed in this publication are those of its authors and do not necessarily reflect the views of ESCAP and CSAM.

Any mention of firm names and commercial products do not imply the endorsement of ESCAP/CSAM.



United Nations  
Centre for Sustainable Agricultural Mechanization

A-7/F, China International Science and  
Technology Convention Centre  
No.12, Yumin Road, Chaoyang District  
Beijing 100029, P.R.China

Tel: (86-10) 8225 3581  
Fax: (86-10) 8225 3584  
info@un-csam.org  
www.un-csam.org