

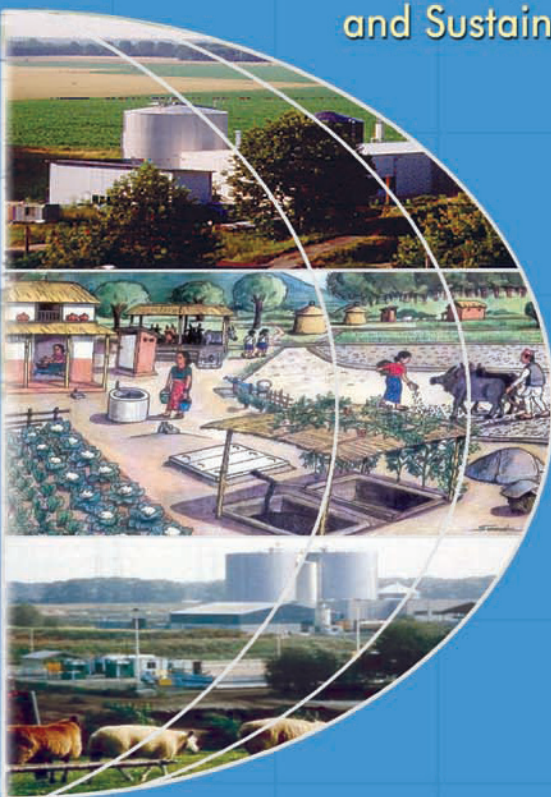

Recent Developments in Biogas Technology for Poverty Reduction and Sustainable Development



United Nations Economic and Social Commission for Asia and the Pacific (ESCAP) is the regional development arm of the United Nations and serves as the main economic and social development centre for the United Nations in Asia and the Pacific. Its mandate is to foster cooperation between its 53 member countries and 9 associate members. ESCAP provides the strategic link between global and country-level programmes and issues. It supports the Governments of the region in consolidating regional positions and advocates regional approaches to meeting the region's unique socio-economic challenges in a globalizing world. The ESCAP headquarters is located in Bangkok, Thailand. Please visit the website at www.unescap.org for further information.



The shaded areas of the the map are ESCAP members and associate members

APCAEM is a regional institution of ESCAP, located in Beijing, China. Its mission is to assist member countries in achieving their Millennium Development Goals (MDGs) through capacity building/training, agricultural policy analysis, agro-technology transfer and facilitation, and information networking. The Centre focuses on three thematic cluster programmes of work: agricultural engineering and machinery, food chain management, and agro-enterprise development. For more information, please visit our website at www.unapcaem.org.

Disclaimer

The designations used and the presentation of the material in this publication do not imply the express opinion on the part of the ESCAP Secretariat concerning the delimitation of its frontiers or boundaries. The views expressed in this publication are those of its authors and do not necessarily reflect the views of ESCAP and APCAEM.

Any mention of firm names and commercial products do not imply the endorsement of ESCAP/ APCAEM.

This publication has been issued without formal editing.

**RECENT DEVELOPMENTS IN
BIOGAS TECHNOLOGY
FOR POVERTY REDUCTION
AND SUSTAINABLE DEVELOPMENT**



United Nations
ESCAP

APCAEM

Beijing, 2007

Preface

The Kyoto Protocol specifies binding commitments by most industrialized countries to reduce greenhouse gas (GHG) emissions. The Clean Development Mechanism (CDM) is one of the three flexible mechanisms established under the Kyoto Protocol. The CDM provides new opportunities for the promotion of biogas in order to reduce the greenhouse effect, through the reduction of methane emission into the atmosphere. Biogas has proven its viability as an energy technology in rural areas of Asia, in particular, India, Nepal, Bangladesh, and China. Over the past 25 years, different types of biogas digesters have been developed and their installation has been commercialized. Technical assistance agencies, bilateral donors and multilateral financing institutions have supported the promotion of biogas technology and assisted the private sector with manufacturing and dissemination of the proper technology. In 2005, the World Bank signed a Memorandum of Understanding that facilitates the trade in emission rights from biogas technology. Biogas projects in Brazil and Chile already apply CDM. Nepal recently signed the Kyoto Protocol in 2005 and biogas programmes are in place which will benefit from the sale of Certified Emission Reductions (CERs) by Nepal. Under a proper policy regime, the income from the sale of CERs can be used to reduce investment costs in biogas equipment. This will accelerate the purchase of biogas digesters by private households and investments in large biogas plants by commercial enterprises, which will further reduce pollution and provide alternative source of affordable energy. There is a potential in Asian and Pacific countries for similar CDM applications.

APCAEM conducted a study on the potential applications of CDM from large-scale industrial biogas plants to small household-type digesters. The study contains a summary on the technical, political, and institutional issues involved in the application of CDM for the Asian and Pacific region. APCAEM sincerely wishes that this study report will contribute to a wider use of the biogas technology for rural poverty reduction and sustainable development.

Table of Contents

EXECUTIVE SUMMARY	1
1. INTRODUCTION	3
1.1 BIOGAS BASICS	3
1.2 TYPES OF BIOGAS PLANTS	6
1.3 BIOGAS APPLIANCES	8
1.4 ORGANIC FERTILIZER FROM BIOGAS PLANTS	15
1.5 CLIMATIC CONDITIONS FOR BIOGAS DISSEMINATION	16
2. CURRENT SITUATION AND RECENT DEVELOPMENTS	21
2.1 DEVELOPMENTS IN LEADING ASIAN COUNTRIES	21
2.2 HOUSEHOLD BIOGAS DEVELOPMENT PROGRAMMES	23
2.3 COMMERCIAL LARGE-SIZE BIOGAS SYSTEMS	26
2.3.1 On-farm biogas systems	26
2.3.2 Community biogas installations	29
2.4 BIOGAS FOR INDUSTRIAL WASTE AND WASTE WATER MANAGEMENT	32
2.5 ANAEROBIC DIGESTION AS PART OF ECOLOGICAL SANITATION	34
3. THE APPLICATION OF CDM TO BIOGAS TECHNOLOGY	37
3.1 POTENTIALS AND CONSTRAINTS OF INTEGRATED BIOGAS SYSTEMS	37
3.2 THE COMMUNITY DEVELOPMENT CARBON FUND	39
4. LESSONS LEARNED AND BEST PRACTICES	43
4.1 BARRIERS IN DEVELOPING CDM PROJECTS	43
4.2 MAIN ISSUES FOR LARGE SCALE BIOGAS PROJECTS	46
4.3 MAIN ISSUES FOR MEDIUM AND SMALL SCALE BIOGAS PROJECT	47
4.4 LIMITATIONS OF CDM AS FINANCING INSTRUMENTS	52
5. STRATEGIES FOR BIOGAS DEVELOPMENT	55
5.1 INVOLVEMENT OF THE PRIVATE SECTOR	55
5.2 INVOLVEMENT OF THE GOVERNMENTAL SECTOR	59
5.3 SNV BIOGAS PROGRAMMES IN ASIA	60
6. CONCLUSIONS AND RECOMMENDATIONS	65
6.1 EXPERIENCES FROM LEADING COUNTRIES	65
6.2 SOCIO-CULTURAL ASPECTS OF BIOGAS PROJECTS	68
6.3 POLITICAL AND ADMINISTRATIVE CONSIDERATIONS	70
ENDNOTES	73

List of Figures

FIGURE 1: A TYPICAL BIOGAS CONFIGURATION	5
FIGURE 2: SIMPLE BIOGAS PLANTS	7
FIGURE 3: INDUSTRIAL BIOGAS PLANT WITH UTILIZATION OF DOMESTIC ORGANIC WASTE	8
FIGURE 4: LIGHTWEIGHT AND STABLE TWO-FLAME GAS BURNERS	9
FIGURE 5: BIOGAS STOVE IN CHINA	9
FIGURE 6: BIOGAS LAMP IN THAILAND	10
FIGURE 7: SCHEMATIC STRUCTURE OF A BIOGAS LAMP	11
FIGURE 8: BIOGAS LAMPS IN CHINA	11
FIGURE 9: GLOBAL 15°C ISOTHERMS FOR JANUARY AND JULY	17
FIGURE 10: SCHEMATIC DIAGRAM OF THE BIOGAS COURTYARD MODEL IN NORTHERN CHINA	24
FIGURE 11: TRADITIONAL ENERGY SUPPLY SYSTEM IN PURA	29
FIGURE 12: PURA'S ALTERNATIVE (MODERN) ENERGY SUPPLY SYSTEM OF THE PURA VILLGE	30
FIGURE 13: CDM PROJECT CYCLE COMPARED WITH CONVENTIONAL PROJECT DEVELOPMENT	45
FIGURE 14: FLOWCHART FOR TESTING ADDITIONALITY OF LARGE SCALE CDM PROJECTS	48

List of Tables

TABLE 1: POTENTIAL GAS PRODUCTION OF SWINE	26
TABLE 2: MANURE PRODUCTION FROM INDIVIDUAL HOGS	26
TABLE 3: MANURE AND GAS PRODUCED BY ONE ANIMAL	27
TABLE 4: CAPITAL COST ESTIMATION (US\$) OF TREATMENT UNITS (US\$)	27
TABLE 5: TOTAL COST ESTIMATION OF BIOGAS SYSTEMS, US\$ (HAWAII, USA)	28
TABLE 6: ROLE OF IBS IN MEETING THE MDGS BY STRENGTHENING THE FIVE CAPITALS	38
TABLE 7: NUMBER OF CDM PROJECT CERS GENERATED	45
TABLE 8: LARGE-SCALE AGRICULTURAL CDM PROJECTS	47
TABLE 9: MEDIUM AND SMALL SCALE AGRICULTURE CDM PROJECTS	49
TABLE 10: TRANSACTION COSTS FOR NORMAL AND SMALL SCALE CDM PROJECTS (US DOLLARS)	50
TABLE 11: SMALL SCALE CDM BIOGAS PROJECTS	52

List of Abbreviations

AEPC	Alternative Energy Promotion Centre
BDT	Bangladesh Taka
BgM	Biogas Manure
BMW	Bio-organic Municipal Wastes
BORDA	Bremen Overseas Research and Development Association
BOT	Build, Operate and Transfer
BSP	Biogas Support Programme
CDCF	Community Development Carbon Fund
CDM	Clean Development Mechanisms
CERs	Certified Emission Reductions
CNY	Chinese Yuan
CO ₂	Carbon Dioxide
DNA	Designated National Authority
ERPA	Emission Reduction Purchase Agreement
FAO	Food and Agriculture Organization
GATE	German Appropriate Technology Exchange
GDP	Gross Domestic Product
GTZ	German Agency for Technical Assistance
IBS	Integrated Biogas Systems
INR	Indian Rupees
IRR	Internal Rate of Return
MDGs	Millennium Development Goals
MFI	Micro Finance Institute
MNES	Ministry of Non-Conventional Energy Sources
MSW	Municipal Solid Wastes
MW	Megawatt
NGO	Non-Governmental Organizations

NPV	Net Present Value
PDD	Project Design Document
UNFCCC	United Nations Framework Convention on Climate Change
USD	US Dollars

EXECUTIVE SUMMARY

Biogas is a proven and widely-used source of energy in Asia. There has been a renewed interest in biogas owing to rising concerns over the greenhouse effect, high price of fossil fuels, and other environmental and health concerns. The Clean Development Mechanism (CDM) opens up new opportunities for the promotion of biogas. As a regional centre, APCAEM is involved in institutional- and policy-related work on agricultural engineering and agro-industry. This publication will be useful for policy- and decision-makers in governments, the donor community, and the private sector dealing with biogas programmes.

The introduction chapter of the publication provides basic information on the different aspects of biogas technology – utilization, types and configurations of biogas digesters, end-use appliances and technologies for biogas, generation of fertilisers as well as additional benefits of biogas generation, and the climatic and environmental considerations for biogas development and applications.

Chapter 2 reviews the current situation and recent developments in biogas in the Asia-Pacific region, focusing on the activities, projects and programmes implemented in the three countries that have led the way in biogas development, applications and commercialization – China, India and Nepal.

Chapter 3 introduces CDM as a possible mechanism for financing biogas projects and discusses the potential of biogas development and application as CDM projects. In particular, the requirements of the Community Development Carbon Fund, a prototype CDM funding mechanism, are presented.

Chapter 4 draws much of its discussion from one of the papers presented at an International Biogas Conference – analyzing the specific barriers for utilizing CDM for financing biogas projects and assessing risk-mitigation strategies that may be implemented to make biogas attractive for CDM financing.

Chapter 5 discusses the current approaches and strategies being undertaken by the countries in the regions that are paving the way for the dissemination and commercialization of biogas technology. The role of the private sector in Nepal and China is presented. The thrusts of the biogas programmes for the other three Asian countries – Bangladesh, Cambodia and Vietnam – are also presented. These approaches, strategies and programmes are aimed at addressing the barriers to commercialization of biogas, including possible sources of CDM for financing biogas investments.

EXECUTIVE SUMMARY

Chapter 6 highlights lessons learned from the experiences of the leading countries and discusses, in particular, the social and economic considerations in formulating and implementing biogas projects. These discussions identify concerns that need to be addressed in order for the potential biogas energy projects to contribute to the socio-economic development of the targeted communities, particularly by improving rural livelihoods of the region.

1. Introduction

Biogas is a proven and widely used source of energy in Asia. There is now yet another wave of renewed interest in biogas due to the increasing concerns of climate change, indoor air pollution and increasing oil prices. Such concerns, particularly for climate change, open opportunities for the use of the Clean Development Mechanism (CDM) in the promotion of biogas.

As a regional centre, the United Nations Asian and Pacific Centre for Agricultural Engineering and Machinery (APCAEM) is involved in institutional- and policy-related programme of agricultural engineering and agro-industry. One of the activities of APCAEM is promoting the application of CDM to agriculture in the Asian and Pacific region.

An International Seminar on Biogas Technology for Poverty Reduction and Sustainable Development was organized by APCAEM in cooperation with the Ministry of Agriculture of China, from 17 to 20 October 2005 in Beijing, China. One of the objectives of this Seminar was to identify innovative developments in biogas technology and the areas of application of CDM. During the roundtable discussion, the follow-up activities were identified:

- Review the materials submitted and presented on biogas technology for poverty reduction and sustainable development.
- Based on the outline of the publication, to publicize the recent development in biogas technology.

APCAEM has prepared this publication to provide information and technology useful to the policy makers in Governments, the donor community, and other key stakeholders in biogas development and commercialization.

1.1 Biogas Basics¹

What is Biogas?

Biogas originates from bacteria during the process of bio-degradation of organic materials under anaerobic (without air) conditions. The natural generation of biogas is an important part of the biogeochemical carbon cycle. Methanogens (methane-producing bacteria) are the last link in the chain of micro-organisms that degrade organic materials and return the decomposed products to the environment. It is in this step of the biogeochemical carbon cycle that biogas, a source of renewable energy, is generated.

Biogas and the Global Carbon Cycle

Each year, some 590-880 million tons of methane are released worldwide into the atmosphere through microbial activity. About 90 percent of the emitted methane derives from biogenic sources,

i.e., from the decomposition of biomass. The remainder is of fossil origin (e.g., petrochemical processes). In the northern hemisphere, the present tropospheric methane concentration amounts to about 1.65 ppm.

Biology of Methanogenesis

Knowledge of the fundamental processes involved in methane fermentation is necessary for planning, building and operating biogas plants. Anaerobic fermentation involves the activities of three different bacterial communities. Biogas production also depends on certain specific conditions. For example, changes in ambient temperature can have a negative effect on bacterial activity.

Substrate and Material Balance of Biogas Production

In general, all organic materials can ferment or be digested. However, only homogenous and liquid substrates can be considered for simple biogas plants: faeces and urine from cattle, pigs and possibly poultry, as well as wastewater from toilets. When the plant is at capacity, the excrement is diluted with an equal quantity of liquid, such as urine if available. Waste and wastewater from food-processing industries are only suitable for simple plants if they are homogenous and in liquid forms. The maximum gas-production from a given amount of raw material depends on the type of substrate.

Composition and Properties of Biogas

Biogas is a mixture of gases mainly composed of:

- Methane (CH_4): 40-70 % by volume
- Carbon dioxide (CO_2): 30-60 % by volume
- Other gases: 1-5 % by volume, including:
 - Hydrogen (H_2): 0-1 % by volume
 - Hydrogen sulfide (H_2S): 0-3 % by volume

Similar to any pure gas, the properties of biogas are pressure- and temperature-dependent. They are also affected by the moisture content and other major factors such as:

- Change in volume as a function of temperature and pressure
- Change in calorific value as a function of temperature, pressure and water-vapor content
- Change in water-vapor content as a function of temperature and pressure

The calorific power of biogas is about 6 kWh/m^3 - this corresponds to about half a litre of diesel oil. The net calorific value depends on the efficiency of the burners or appliances. Methane is the most valuable component if the biogas is to be used as a fuel.

Utilization

The historical evidence of biogas utilization shows independent developments in various developing and industrialized countries. Normally, the biogas produced by a digester can be used as is, the same way as any other combustible gas. It is possible that further treatment or conditioning is necessary, for example, to reduce the hydrogen-sulfide content in the gas. When biogas is mixed with air at a ratio of 1:20 a highly explosive gas forms; therefore, leaking gas pipes in enclosed spaces poses a hazard.

Figure 1: Typical biogas configuration

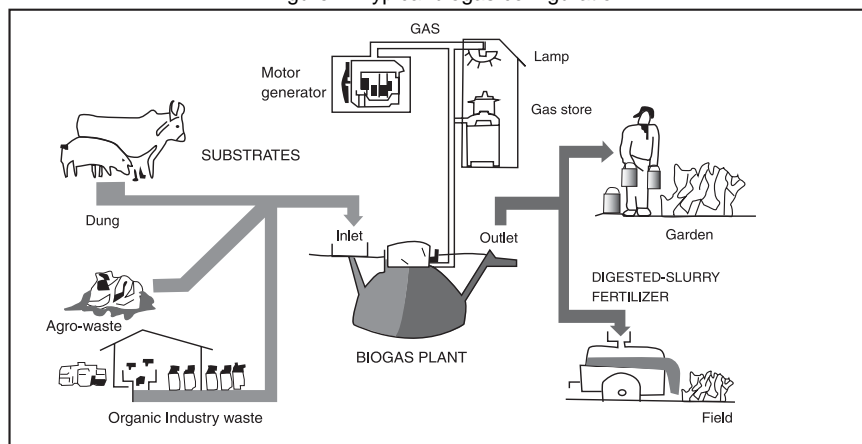

Source: GTZ Biogas Basics.

Benefits of Biogas Technology

Well-functioning biogas systems can yield a range of benefits for users, the society and the environment in general:

- Production of energy (heat, light, electricity);
- Transformation of organic wastes into high-quality fertiliser;
- Improvement of hygienic conditions through reduction of pathogens, worm eggs and flies;
- Reduction of workload, mainly for women, in firewood collection and cooking;
- Positive environmental externalities through protection of soil, water, air and woody vegetation;
- Economic benefits through energy and fertiliser substitution, additional income sources and increasing yields of animal husbandry and agriculture;
- Other economic and eco-benefit through decentralized energy generation, import substitution and environmental protection.

Biogas technology can substantially contribute to conservation and development, if the concrete conditions are favourable. However, the required high level of investment in capital and other limitations of biogas technology should also be thoroughly considered.

Affordability of Biogas Technology

An obvious obstacle to the large-scale introduction of biogas technology is the fact that the poorer strata of rural populations often cannot afford the initial investment cost for a biogas plant. This barrier remains despite the fact that biogas systems have proven to be economically sound investments in many cases.

Efforts must be made not only to reduce construction costs, but also to develop credit and other financing mechanisms for biogas technology. A larger number of biogas operators ensure that, apart from the private user, the society as a whole can benefit from the use of biogas. Financial support from the government can be seen as an investment to curb future costs incurred through the importation of petrol products and inorganic fertilisers, increasing costs for health and hygiene, as well as natural resource degradation.

Fuel and Fertiliser

In developing countries, there is a direct link between the problem of fertilization and progressive deforestation due to a high demand for firewood. In many rural areas, most inhabitants are dependent on dung and organic residue as fuel for cooking and heating.

Such is the case, for example, in the treeless regions of India (Ganges plains, central highlands), Nepal and other countries of Asia, as well as in the Andes mountains of South America and wide expanses of the African Continent. According to the data published by the FAO, some 78 million tonnes of cow dung and 39 million tonnes of phytogenic waste were burned in India alone in 1970. That amounts to approximately 35 percent of India's total non-commercial/non-conventional energy consumption.

The burning of dung and plant residue is a considerable waste of plant nutrients. Farmers in developing countries are in dire need of fertiliser for maintaining cropland productivity. Nonetheless, many small farmers continue to burn potentially valuable natural fertilisers, despite being unable to afford chemical fertilisers. The amount of technically available nitrogen, potassium and phosphorous in the form of organic materials is around eight times as high as the quantity of chemical fertilisers actually consumed in developing countries. Biogas technology is a suitable tool, especially for small farmers, for maximizing the use of scarce resources. After extraction of the energy content of dung and other organic waste material, the resulting sludge is still a good fertiliser, supporting soil quality as well as higher crop yields.

1.2 Types of Biogas Plants²

The three main types of simple biogas plants are shown in Figure 2:

- Balloon plants
- Fixed-dome plants
- Floating-drum plants

Balloon Plants

The balloon plant consists of a digester bag (e.g., PVC) in the upper part in which the gas is stored. The inlet and outlet are attached directly to the plastic skin of the balloon. The gas pressure is achieved through the elasticity of the balloon and by added weights placed on the balloon.

The advantages of this system are its low cost, ease of transportation, low construction sophistication, high digester temperatures, and its rather simple cleaning, emptying and maintenance.

The disadvantages can be the relatively short life span, high susceptibility to damage, little creation of local employment and, therefore, limited self-help potential.

A variation of the balloon plant is the channel-type digester, which is usually covered with plastic sheeting and a sunshade (see Figure 2E). Balloon plants can be recommended wherever the balloon skin is not likely to be damaged and where temperatures are not too high.

Figure 2: Simple biogas plants

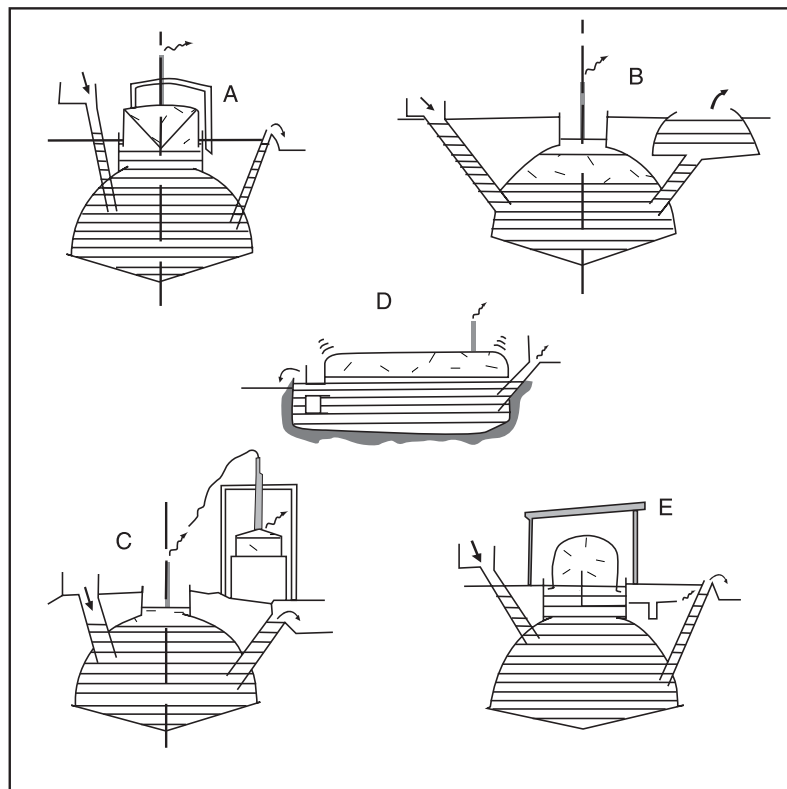

Note: Floating-drum plant (A), fixed-dome plant (B), fixed-dome plant with separate gas holder (C), balloon plant (D), channel-type digester with plastic sheeting and sunshade (E).
Source: Biogas Plants, L. Sasse, GATE, 1988, p.14.

Fixed-Dome Plants

The fixed-dome plant consists of a digester with a fixed, non-movable gas holder, which sits on top of the digester. When the production of gas starts, the slurry is displaced into the compensation tank. The gas pressure increases with the volume of gas stored and the height difference between the slurry level in the digester and the slurry level in the compensation tank.

The advantages of this system are the relatively low construction costs and the absence of moving parts and rusting steel parts. If well-constructed, fixed-dome plants have a long life span. The underground construction saves space and protects the digester from temperature changes. The construction provides opportunities for skilled local employment.

The disadvantages are mainly the frequent problems with the gas-tightness of the brickwork gas holder, where even a small crack in the upper brickwork can cause a heavy loss of biogas. Therefore, fixed-dome plants are recommended only where construction can be supervised by experienced biogas technicians. The gas pressure fluctuates substantially depending on the volume of the stored gas. Even though the underground construction buffers temperature extremes, digester temperatures are low.

Floating-Drum Plants

Floating-drum plants consist of an underground digester and a moving gasholder. The gasholder floats either directly on the fermentation slurry or in a water jacket of its own. The gas is collected in the gas drum, which rises or moves down, according to the amount of gas stored. The gas drum is prevented from tilting by a guiding frame. If the drum floats in a water jacket, it cannot get stuck, even in substrate with a high solid content.

The main advantage of this system is its simple, easy operation, as the volume of stored gas is directly visible to the user. The gas pressure is constant and determined by the weight of the gas holder. The construction is relatively easy and mistakes do not lead to major problems in operation or gas yield.

The disadvantages are high material costs of the steel drum and the susceptibility of steel parts due to corrosion. Because of this, floating-drum plants have a shorter life span than fixed-dome plants and regular maintenance costs for the painting of the drum.

To contrast these simple biogas plants, Figure 3 gives an impression about dimensions of industrial plants that have been built in Europe.

Figure 3: Industrial biogas plant with utilization of domestic organic waste

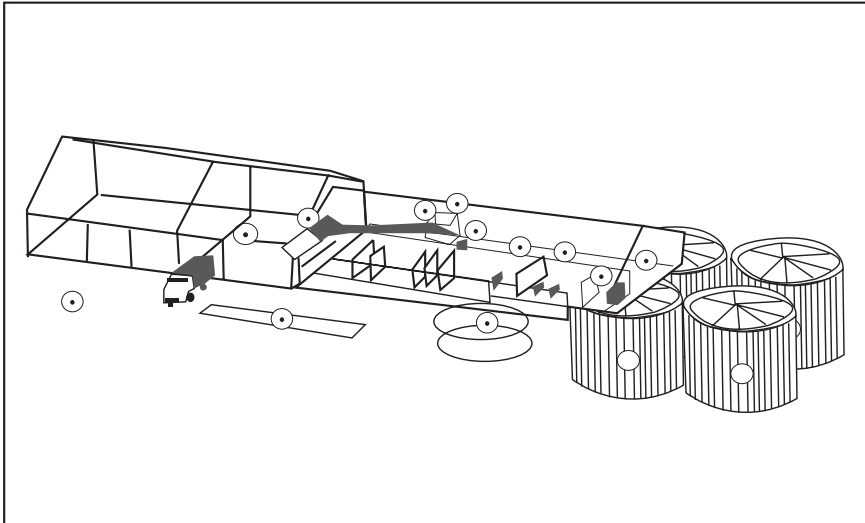

Source: GTZ.

1.3 Biogas Appliances³

Biogas is a lean gas that can, in principle, be used like other fuel gases for households and industrial purposes:

- Gas cookers/stoves
- Lamps
- Radiant heaters
- Incubators

- Refrigerators
- Engines

Gas Cookers/Stoves

Biogas cookers and stoves must meet various basic requirements:

- Simple and easy operation
- Versatility, e.g., for pots of various size, for cooking and broiling
- Easy to clean, acceptable cost and easy repair
- Good burning properties, i.e., stable flame, high efficiency
- Agreeable appearance

Two-flame burners

A cooker is more than just a burner. It must satisfy certain aesthetic and utility requirements, which can vary widely from region to region. There is no such thing as a standard biogas burner. Most households prefer two-flame burners. The burners should be set initially and then fixed so that efficiency remains at a high practical level. Single-flame burners and lightweight cook-stoves tend to be regarded as stop-gap solutions until more suitable alternatives can be found.

Figure 4: Lightweight and stable two-flame gas burners

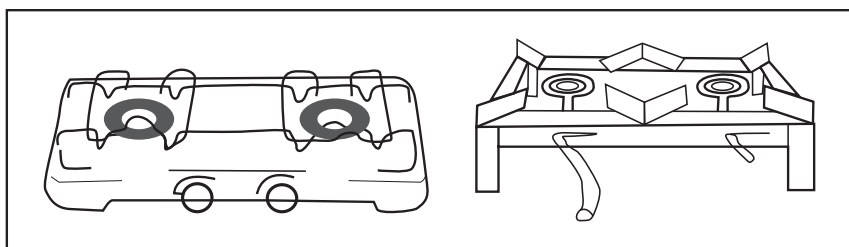

Source: GTZ.

Biogas cookers require careful installation with adequate protection from the wind. Before any cooker is used, the burner must be carefully adjusted.

- For a compact, bluish flame the pot should be cupped by the outer cone of the flame without being touched by the inner cone;
- The flame should be self-stabilizing, i.e., flameless zones must re-ignite automatically within 2 to 3 seconds.

Test measurements should be performed to optimize the burner setting and minimize consumption.

Figure 5: Biogas Stove in China



Source: Grosch, GTZ/GATE.

Gas demand

The gas demand can be defined on the basis of energy consumed previously. For example, 1 kg firewood then corresponds to 200 litres biogas, 1 kg dried cow dung corresponds to 100 litres biogas and 1 kg charcoal corresponds to 500 litres biogas.

The gas demand can also be defined using the daily cooking times. The gas consumption per person and meal lies between 150 and 300 litres biogas. For one litre of water to be boiled, 30-40 litre of biogas are required, for 1/2 kg rice 120-140 litres, and for 1/2 kg legumes 160-190 litres.

Lamps

Efficiency of biogas lamps

In villages without electricity, lighting is not only a basic need, but also a status symbol. However, biogas lamps currently provide little relief as they are not very energy-efficient and they tend to get very hot. The bright light of a biogas lamp is the result of incandescence, i.e., the intense heat-induced luminosity of special metals, so-called “rare earth” metals like thorium, cerium, lanthanum, etc., at temperatures of 1,000-2,000°C. If they hang directly below the roof, they pose a potential fire hazard. Also, the mantles do not last long. It is important that the gas and air in a biogas lamp are thoroughly mixed before they reach the gas mantle, and that the air space around the mantle is adequately warm.

Light output

The light output (luminous flux) is measured in lumen (lm). At 400-500 lm, the maximum light-flux values that can be achieved with biogas lamps are comparable to those of a normal 25-75 W light bulb. Their luminous efficiency ranges from 1.2 to 2 lm/W. By comparison, the overall efficiency of a light bulb comes to 3-5 lm/W, and that of a fluorescent lamp ranges from 10 to 15 lm/W. One lamp consumes about 120-150 litres of biogas per day.

Optimal tuning

The performance of a biogas lamp is dependent on optimal tuning of the incandescent body (gas mantle) and the shape of the flame at the nozzle, i.e., the incandescent body must be surrounded by the inner (and hottest) core of the flame at the minimum gas consumption rate. If the incandescent body is too large, it will show dark spots; if the flame is too large, gas consumption will be too high for the light-flux yield. The lampshade reflects the light downward, and the glass prevents the loss of heat.

Figure 6: Biogas lamp in Thailand



Source: Kossman, GTZ/GATE.

Shortcomings of commercial-type biogas lamps

Practical experience shows that commercial-type gas lamps are not optimally designed for the specific conditions of biogas combustion (fluctuating or low pressure, variable gas composition).

The most frequently observed shortcomings are:

- Excessively large nozzle diameters;
- Excessively large gas mantles;
- No possibility of changing the injector;
- Poor or lacking means of combustion-air control.

Such drawbacks result in unnecessarily high gas consumption and poor lighting. While the expert/extension officer has practically no influence on how a given lamp is designed, s/he can at least give due consideration to the mentioned aspects when it comes to selecting a particular model.

Figure 7: Schematic structure of a biogas lamp¹

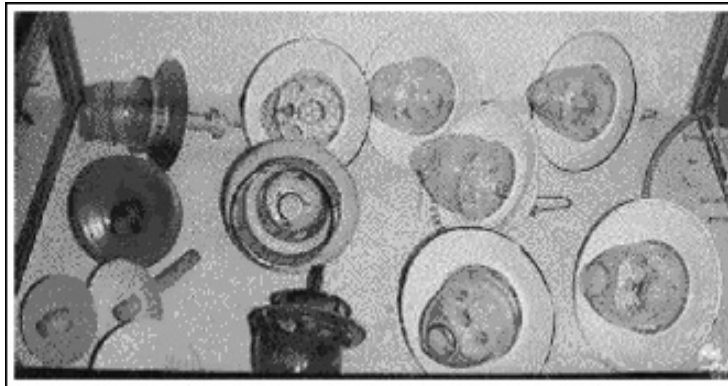
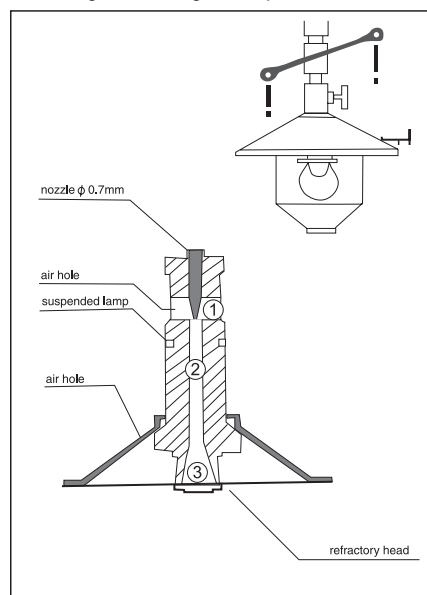

Figure 8: Biogas lamps in China



Source: Grosch, GTZ/GATE.

¹ Photo: Production and Utilization of Biogas in Rural Areas of Industrialized and Developing Countries, Schriftenreihe der gtz No. 97, p.186.

Radiant Heaters

Infrared heaters are used in agriculture for achieving the temperatures required for raising young stock, e.g., piglets and chicken, in a limited amount of space. The nursery temperature for piglets begins at 30-35°C for the first week and then gradually drops off to an ambient temperature of 18-23°C in the 4th/5th week. Temperature control consists of raising or lowering the temperature. Good ventilation is important in the stable nursery in order to avoid excessive concentrations of CO or CO₂. Consequently, the animals must be kept under regular supervision, and the temperature must be checked at regular intervals. Heaters for pig or chicken rearing require some 200-300 l/h in general.

Thermal radiation of heaters

Radiant heaters develop their infrared thermal radiation via a ceramic body that is heated to 600-800°C (red-hot) by the biogas flame. The heating capacity of the radiant heater is defined by multiplying the gas flow by its net calorific value, since 95 percent of the biogas energy content is converted to heat. Small-heater outputs range from 1.5 to 10 kW thermal power.

Gas pressure

Commercial-type heaters are designed for operating on butane, propane and natural gas at a supply pressure of between 30 and 80 mbar. Since the primary air supply is factory-set, converting a heater for biogas-use normally consists of replacing the injectors. However, experience shows that biogas heaters rarely work satisfactorily because the biogas has a low net calorific value and the gas supply pressure is below 20 mbar. The ceramic panel, therefore, is not adequately heated, i.e., the flame does not reach the entire surface, and the heater is very susceptible to drafts.

Safety pilot and air filter

Biogas-fuelled radiant heaters should always be equipped with a safety pilot, which turns off the gas supply if the temperatures go too low, i.e., the biogas does not burn any longer. An air filter is required for sustained operation in dusty barns.

Incubators

Incubators are supposed to imitate and maintain optimal hatching temperatures for eggs. They are used to increase brooding efficiency.

Warm-water-heated planar-type incubators

Indirectly warm water-heated planar-type incubators, in which a burner heats water in a heating element for circulation through the incubating chamber, are suitable for operating on biogas. The temperature is controlled by ether cell-regulated vents.

Biogas-Fuelled Engines

Gas demand

If the output of a biogas system is to be used for fueling engines, the plant must produce at least 10 m³/day of biogas. For example, to generate 1 kWh of electricity with a generator, about 1.0 m³ biogas is required. Small-scale systems are therefore not suitable as energy suppliers for engines.

Types of engines

The following types of engines are, in principle, well-suited for operating on biogas:

- Four-stroke diesel engines
- Four-stroke spark-ignition engines
- Converting diesel engines
- Converting spark-ignition engines

Four-stroke diesel engines

A diesel engine draws in air and compresses it at a ratio of 17:1 under a pressure of approximately 30-40 mbar and a temperature of about 700°C. The injected fuel charge ignites itself. Power output is controlled by varying the injected amount of fuel, i.e., the air intake remains constant, which results in a so-called “mixture control”.

Four-stroke spark-ignition engines

A spark-ignition engine, or gasoline engine, draws a mixture of fuel (gasoline or gas) and the required amount of combustion air. The charge is ignited by a spark plug at a comparably low compression ratio of between 8:1 and 12:1. Power control is affected by varying the mixture intake via a throttle or charge control.

Four-stroke diesel and spark-ignition engines are available in standard versions with power ratings ranging from 1 kW to more than 100 kW. Less suitable for biogas fuelling are:

- Loop-scavenging 2-stroke engines in which lubrication is achieved by adding oil to the liquid fuel
- Large, slow-running (less than 1,000 rpm.) engines that are not built in large series since they are expensive and require complicated control equipment.

Biogas engines are generally suitable for powering vehicles like tractors and light-duty trucks such as pickups and vans. The fuel is contained in 200-bar steel welding-gas cylinders. The technical, safety and energy costs of gas compression, storage and filling is substantial enough to hinder large-scale applications.

Converting diesel engines

Diesel engines are designed for continuous operation (10,000 or more operating hours). For this reason they are well-suited for conversion to biogas utilization according to either of the following two methods.

In the dual-fuel approach, the diesel engine remains essentially unmodified, except for the addition of a gas/air mixing chamber on the air-intake manifold, as the air filter can be used as a mixing chamber. The injected diesel fuel still ignites itself, while the amount injected is automatically reduced by the speed governor, depending on how much biogas is injected into the mixing chamber. The biogas supply is controlled by hand. The maximum biogas intake must be kept below the point at which the engine begins to stutter. If that happens, the governor gets too much biogas and has turned down the diesel intake to an extent that ignition is no longer steady. Normally, 15-20 percent diesel is sufficient. As much as 80 percent of the diesel fuel can thus be replaced by

Introduction

biogas. Any lower share of biogas can also be used, since the governor automatically compensates with more diesel.

Dual-fuel diesels perform just as well as comparable engines operating on pure diesel. As in normal diesel operation, the speed is controlled by an accelerator lever, and load control is normally controlled by hand, i.e. by adjusting the biogas valve, keeping in mind the maximum acceptable biogas intake level. In the case of frequent power changes at steady speeds, the biogas intake should be somewhat reduced to let the governor decrease the diesel intake without transgressing the minimum diesel intake. That ensures that speed is kept constant, even in the case of power fluctuations. It is important to note that no diesel engine should be subjected to air-side control.

While special T-pieces or mixing chambers with a volume of 50 to 100 percent of the engine cylinder volume can serve as the diesel / biogas mixing chamber, a proper mixing chamber offers the advantage of more thorough mixing.

To sum up, conversion according to the dual-fuel method:

- is a quick and easy do-it-yourself technique;
- accommodates an unsteady supply of biogas;
- is well-suited for steady operation, since a single manual adjustment will suffice;
- requires a minimum share of diesel to ensure ignition

Conversion to Spark Ignition (Otto cycle) involves the following permanent modifications to the engine:

- Removing the fuel-injection pump and nozzle
- Adding an ignition distributor and an ignition coil with power supply (battery or dynamo)
- Installing spark plugs in place of the injection nozzles
- Adding a gas mixing valve or carburettor
- Adding a throttle control device
- Reducing the compression ratio (ratio of the maximum to the minimum volume of the space enclosed by the piston) to 11-12

Converting a diesel engine to a biogas-fueled spark-ignition engine is expensive and complicated. Only pre-converted engines of that type should be procured. Engines with a pre-combustion or swirl chamber are not suitable for such conversion.

Converting spark-ignition engines

Converting a spark-ignition engine for biogas fueling requires replacement of the gasoline carburettor with a mixing valve (pressure-controlled venturi type or with throttle). The spark-ignition principle is retained, however, should be advanced as necessary to account for slower combustion (approx. 5° - 10° crankshaft angle) and to avoid overheating of the exhaust valve while precluding loss of energy due to still-combustible exhaust gases. The engine speed should be limited to 3,000 rpm for the same reason. As in the case of diesel-engine conversion, a simple mixing chamber should normally suffice for continuous operation at a steady speed. In addition, the

mixing chamber should be equipped with a hand-operated air-side control valve for use in adjusting the air/fuel ratio (optimal “actual air volume/stoichiometric air volume” = 1.1).

The conversion of a spark-ignition engine results in a loss of as much as 30 percent of performance. While partial compensation can be achieved by raising the compression ratio to $E=11-12$, such a measure also increases the mechanical and thermal load on the engine. Spark-ignition engines that are not explicitly marketed as suitable for running on gas or unleaded gasoline may suffer added wear and tear due to the absence of lead lubrication.

The speed control of converted spark-ignition engines is affected by way of a hand-operated throttle. Automatic speed control for different load conditions requires the addition of an electronic control device for the throttle.

The conversion of spark-ignition engines is evaluated as follows:

- Gasoline engines are readily available in the form of vehicle motors, but their life span amounts to a mere 3,000-4,000 operating hours;
- The conversion effort essentially consists of adding a (well-turned) gas mixer.

1.4 Organic Fertiliser from Biogas Plants⁴

Organic Substances in Fertilisers

While there are suitable inorganic substitutes for the nutrients nitrogen, potassium and phosphorous from organic fertiliser, there are no artificial substitutes for other substances such as protein, cellulose, lignin, etc. They all contribute to increasing soil's permeability and hygroscopicity while preventing erosion and improving agricultural conditions in general. Organic substances also constitute the basis for the development of the microorganisms responsible for converting soil nutrients into a form that can be readily incorporated by plants.

Nutrients and soil organisms

Due to the decomposition of parts of its organic content, digested sludge provides fast-acting nutrients that easily enter into the soil solution, thus becoming immediately available to the plants. They simultaneously serve as primary nutrients for the development of soil organisms, e.g. the replenishment of microorganisms, lost through exposure to air in the course of spreading sludge over the fields. They also nourish *actinomycetes* (ray fungi) that act as organic digesting specialists in the digested sludge. Preconditions for the success of this process is adequate aeration and moderate moisture-levels.

Reduction of soil erosion

The humic matter and humic acids present in the sludge contribute to a more rapid humification, which in turn helps reduce the rate of erosion due to rain and dry scatter, while increasing the nutrient supply, hygroscopicity, etc. The humic content is especially important in low-humus tropical soils. The relatively high proportion of stable organic building blocks such as lignin and certain cellulose compounds contributes to an unusually high formation rate of stable humus, particularly

in the presence of argillaceous matter. The amount of stable humus formed with digested sludge amounts to twice the amount that can be achieved with decayed dung. It has also been shown that earthworm activity is stimulated more by fertilizing with sludge than with barnyard dung.

Digested sludge decelerates the irreversible bonding of soil nutrients with the aid of its ion exchanger contents in combination with the formation of organic-mineral compounds. At the same time, the buffering capacity of the soil increases, and temperature fluctuations are better compensated.

Reduction of nitrogen washout

The elevated ammonium content of digested sludge helps reduce the rate of nitrogen washout as compared to fertilisers containing substantial amounts of more water-soluble nitrates and nitrites (dung, compost). Nitrogen in soil, that is in the nitrate or nitrite form, is also subject to higher denitrification losses than in ammonium, which first requires nitrification in order to assume a denitrifiable form. It takes longer for ammonium to seep into deeper soil strata, in part because it is more easily adsorbed by argillaceous bonds. However, some of the ammonium becomes fixed in a non-interchangeable form in the intermediate layers of clay minerals. It is proven that ammonium constitutes the more valuable form of nitrogen for plant nutrition. Certainly the N-efficiency of digested sludge may be regarded as comparable to that of chemical fertilisers.

In addition to supplying nutrients, sludge also improves soil quality by providing organic mass. The porosity, pore-size distribution and stability of soil aggregate are becoming increasingly important as standards of evaluation in soil-quality analysis increase.

Effects on crops

Crop yields are generally acknowledged to be higher following fertilization with digested sludge. Most vegetable crops such as potato, radish, carrot, cabbage, onion, garlic, etc., and many types of fruit (orange, apple, guava, mango, etc.), sugar cane, rice and jute appear to react favourably to sludge fertilization.

In contrast, crops such as wheat, oilseed, and cotton react less favourably. Sludge is a good fertiliser for pastures and meadows. The available data vary widely, because the fertilizing effect is not only plant-specific, but also dependent on the climate and type of soil. Information is still severely lacking on the degree of reciprocity between soil fertility, type of soil and the effect of fertilisers (particularly N-fertilisers) in arid and semi-arid climates. Thus, no definitive information can be offered to date, nor is it possible to offer an economic comparison of the cost of chemical fertilisers to biogas sludge. The only consensus is that can biogas sludge is more desirable from an ecological point of view.

1.5 Climatic Conditions for Biogas Dissemination⁵

Temperatures

Biogas technology is feasible in principle under almost all climatic conditions. As a rule, however,

it can be stated that the cost for biogas production increases in locations with lower average temperatures. In cases of low temperatures, either a heating system has to be installed or a larger digester has to be built in order to increase the retention time. Unheated and un-insulated plants do not work satisfactorily when the mean temperature is below 15°C. Heating system and insulation can provide optimal digestion temperatures even in cold climates and during winter, but the investment costs and the gas consumption for heating may reduce the economic viability of the biogas system.

The mean temperature is important, but any temperature changes can affect the performance of a biogas plant adversely. This includes both day-to-night changes and seasonal variations. For household plants in rural areas, the planner should ensure that the gas production is sufficient even during the most unfavourable season of the year. Within limits, low temperatures can be compensated for with a longer retention time, i.e., a larger digester. The changing of the temperature during the course of the day is rarely a problem as most simple biogas digesters are built underground.

Precipitation

The amount of seasonal and annual rainfall has mainly an indirect impact on anaerobic fermentation:

- Low rainfall or seasonal water scarcity may lead to insufficient mixture of the substrate with water. The negative flow characteristics of substrate can hamper digestion.
- Low precipitation generally leads to less intensive systems of animal husbandry. Less dung is available in central locations.
- High precipitation can lead to high groundwater levels, causing problems in construction and operation of biogas plants.

Suitability of Climatic Zones

- Tropical Rain Forest: Annual rainfall above 1,500 mm, mean temperatures between 24 and 28°C with little seasonal variation. Climatically very suitable for biogas production. Often animal husbandry is hampered by diseases like trypanosomiasis, leading to virtual absence of substrate.
- Tropical Highlands: Rainfall between 1,000 and 2,000 mm, mean temperatures between

Figure 9: Global 15°C isotherms for January and July (Indicating the biogas-conductive temperature zone)

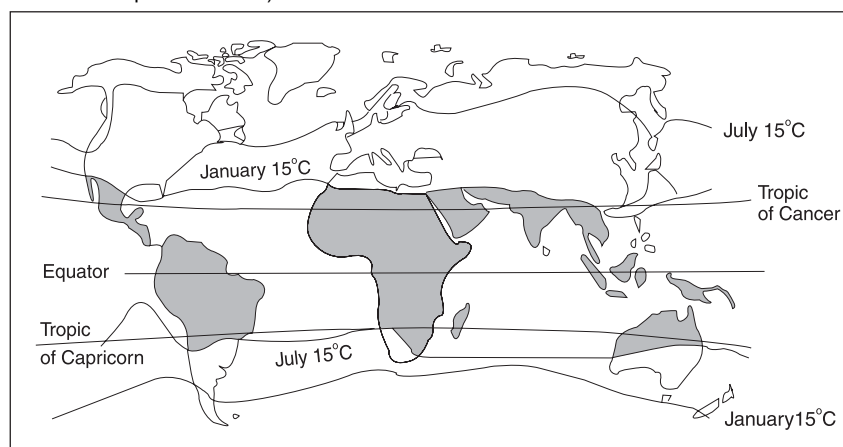

Source: GTZ.

18 and 25°C (according to elevation). Climatically suitable, often agricultural systems highly suitable for biogas production (mixed farming, zero-grazing).

- Wet Savanna: Rainfall between 800 and 1,500 mm, moderate seasonal changes in temperature. Mixed farming with night stables and day grazing favours biogas dissemination.
- Dry Savanna: Seasonal water scarcity, seasonal changes in temperatures. Pastoral systems of animal husbandry, therefore, little availability of dung. Use of biogas possible near permanent water sources or on irrigated, integrated farms.
- Thornbush Steppe and Desert: Permanent scarcity of water. Considerable seasonal variations in temperature. Extremely mobile forms of animal keeping (nomadism). Unsuitable for biogas dissemination.

Firewood Consumption and Soil Erosion

A unique feature of biogas technology is that it simultaneously reduces the need for firewood and improves soil fertilization, thus substantially reducing the threat of soil erosion. While most firewood is not acquired by actually cutting down trees, but rather by cutting off individual branches so that the tree does not need to suffer permanent damage, a substantial amount of firewood is also obtained through illegal felling. In past years, the consumption of firewood has steadily increased, and will continue to do so as the population expands – unless adequate alternative sources of energy are developed, such as biogas, or sustainable tree production for fuel-wood consumption is attained.

Soil Protection and Reforestation

The widespread production and utilization of biogas is expected to make a substantial contribution to soil protection and amelioration. First, biogas could rapidly replace firewood as a source of energy. Second, biogas systems yield not only higher quantity of fertiliser, but also higher quality. As a result, more fodder becomes available for domestic animals. This, in turn, can lessen the danger of soil erosion attributed to overgrazing. According to the ICAR paper (report issued by the Indian Council of Agricultural Research, New Delhi), a single biogas system with a volume of 100 cubic feet (2.8 m³) can save as much as 0.3 acres (0.12 ha) of woodland each year.

Taking India as an example, and assuming a biogas production rate of 0.36 m³/day per livestock unit, some 300 million head of cattle would be required to produce enough biogas to cover the present consumption of firewood. This figure is somewhat in excess of the present cattle stock. If, however, only the amount of firewood normally obtained by way of deforestation (25.2 million trees per year) were to be replaced by biogas, the dung requirement could be satisfied by 55 million cattle. Firewood consumption could be reduced to such an extent that – at least under the prevailing conditions – a gradual regeneration of India's forests would be possible.

According to empirical data gathered in India, the consumption of firewood in rural households equipped with a biogas system is much lower than before, but has not been fully replaced. This is mainly due to a number of technical and operational shortcomings. At the moment, many biogas systems are too small to handle the available supply of substrate or are operated inefficiently. Many existing biogas units sit unused because of minor mistakes made in their manufacture. In addition, biogas users zealously increase their energy consumption to wasteful levels often due

to the ease with which biogas energy is created, which causes energy demand beyond the level of their biogas production, requiring additional energy from firewood.

A more serious problem is that a household biogas system programme can only reach the small percentage of farmers who have the investment capital required. The majority of rural households will continue to use firewood, dried cow dung and harvest residues as fuel.

Reduction of the Greenhouse Effect

Last but not least, biogas technology takes part in the global struggle against the greenhouse effect by reducing the release of CO₂ from burning fossil fuels in two ways. First, biogas is a direct substitute for gas or coal for cooking, heating, electricity generation and lighting. Second, the reduction in the consumption of artificial fertiliser avoids carbon dioxide emissions that would otherwise come from the fertiliser-producing industries. By helping to counter deforestation and degradation caused by overusing ecosystems as sources of firewood and by melioration of soil conditions, biogas technology reduces CO₂ releases from these processes and sustains the capability of forests and woodlands to act as a carbon sink.

Methane, the main component of biogas is itself a greenhouse gas with a much higher "greenhouse potential" than CO₂. Converting methane to carbon dioxide through combustion is another contribution of biogas technology in the mitigation of global warming. However, this holds true only for the case that the material used for biogas generation would otherwise undergo anaerobic decomposition, thereby releasing methane into the atmosphere. Methane leaking from biogas plants without being burned does contribute to the greenhouse effect. Burning biogas also releases CO₂. Similar to the sustainable use of firewood, this returns carbon dioxide which has been assimilated from the atmosphere by growing plants. There is no net intake of carbon dioxide in the atmosphere from biogas burning, as is the case when burning fossil fuels.

2. Current Situation and Recent Developments

2.1 Developments in Leading Asian Countries⁶

Production of biogas through anaerobic digestion is a relatively simple carbon-reducing technology that can be implemented at commercial, village and household levels. It allows for the controlled management of large amounts of animal dung and the safe production of gas for cooking, lighting or power generation. In addition, a by-product of the process provides an extremely valuable agricultural fertiliser. The use of household biogas is most widespread in Asia. In China, over 15 million households use biogas, and successful programmes have been established in Nepal and Vietnam. The international seminar on biogas technology held in Beijing, China, in October 2005 strongly illustrated the renewed interest shown in the application of anaerobic digestion in Asia and the Pacific region. Already, plans exist to spread biogas programmes throughout Asia.

In 2000, the Ministry of Agriculture of China began to introduce various technologies into rural areas, introducing new policies such as “ecological homeland” and the “plan to enrich people”. A domestic biogas plant forms the base and combines with other “transformations” that are dependent on local conditions. These include pig farming as well as the construction of toilets, kitchens, solar-heated greenhouses, orchards and cisterns. Investment subsidies for biogas plants from the central government depend on the level of regional or sub-national economic development.

According to the Chinese Ministry of Agriculture, 15 million households in rural China were using biogas by the end of 2004. The Ministry aims to increase this number to 27 million by 2010, which will account for over ten percent of all rural households. By the end of 2005 there were 2,492 medium and large-scale biogas digesters in livestock and poultry farms, while 137,000 biogas tanks had been constructed for the purification of household wastewater. In Sichuan Province alone 2.58 million domestic biogas plants had been constructed by the end of 2004. This number will increase to five million by the end of 2010. The price for each system ranges between 1,200 and 1,500 RMB (•120-150), while the government subsidy ranges from 800 to 1,000 RMB (•80-100).

In order to promote this growth, the new Renewable Energy Law of the People’s Republic of China came into force on 1 January 2006, following its approval in 2005. This law establishes five systems to support the development of renewable energy resources – market fostering and protection, resource exploitation and planning, technical and industrial support, price support and cost sharing; and financial support and economic stimulation.

In India, the Ministry of Non-Conventional Energy Sources (MNES) continues to implement the National Biogas and Manure Management Programme (NBMMP) through State nodal depart-

Current Situation and Recent Developments

ments and agencies, the Khadi and Village Industries Commission (KVIC) and a number of NGOs. Several grass-root level voluntary agencies and self-employed trained workers are also being involved by these agencies in promoting and constructing biogas plants as well as providing maintenance services. MNES provides financial assistance for the construction and maintenance of biogas plants, training and awareness creation, technical centres, and service charges or salary support to implementing agencies. Against an estimated potential of 12 million domestic biogas plants in the country, a total number of 3.67 million biogas units had been installed by the end of the 2004 fiscal year. Construction rates in the most recent years have been falling from their peak of 200,000 plants per annum. During the financial year 2004-2005, the Regional Offices of the Ministry has conducted inspections on 3,825 biogas plants installed over the previous three years. Out of these, 93 percent were found to be functional.

Biogas production can also be installed in combination with sanitation. Public toilets incorporating biogas units are particularly suitable for pen-urban areas and small towns in India where the supply of cooking gas is inadequate and wastewater treatment is unaffordable for the local authorities. Biogas systems can become part of decentralized wastewater treatment, and provide the fuel needed for heating water, for bathing and running generators to provide lighting in these facilities. The Sulabh International Social Service Organization has constructed about 1.2 million household toilets and more than 6,000 community toilet complexes, yet only about 150 of these community complexes (2.5 percent) include a biogas digester. This is mainly because the local bodies that provide funding are unaware of the importance of biogas systems and opt for a septic tank system.

As many as 17,803 domestic biogas plants were installed from 2004 to 2005, bringing the total number installed under Nepal's Biogas Support Programme (BSP) since 1992 to over 140,000. Specifically, the programme worked in association with the Alternate Energy Promotion Centre (AEPC) in Nepal to secure government and donor support from the Netherlands (DGIS) and Germany and to further promote the use of biogas in Nepal. It has worked in partnership with micro-finance and banking institutions both internationally and domestically to design and implement affordable consumer credit schemes that allow rural farmers to purchase biogas systems. BSP worked very closely with the private sector biogas construction companies and biogas appliance vendors, providing them with technical and management training to ensure that these firms were able to meet the strict standards, control costs and increase production capacity with the growing demand for biogas. Collaboration with various NGOs was maintained to promote the spread of biogas. Most recently, an application for registration was successfully submitted to the Clean Development Mechanism (CDM) Executive Board for the Certified Emission Reductions (CERs) credits associated with the biogas programme in Nepal.

The involvement of the private sector is one of the main factors for this success. There are now 62 biogas construction companies established in the country, along with 15 workshops for the manufacturing of biogas appliances and about 140 micro-finance institutes involved in biogas lending in rural areas.

There are both strengths and weaknesses in the involvement of the private sector in the BSP. Private sector involvement led to the expansion of the biogas market and helped maintain the

product quality standards established by the BSP. However, it has also discouraged development of long-term vision and planning, sometimes resulting in unhealthy competition and lack of initiative to operate in more remote areas, which confines the benefits of the technology solely to higher income rural families.

The BSP has convincingly demonstrated that biogas technology positively affects the lives of farmers, especially women and children, in rural areas. The social and environmental conditions of about 800,000 people have improved, making the BSP a good example of a successfully scaled-up technology.

2.2 Biogas Development Programmes for Households

The Ecological Courtyard Model in Northern China⁷

Biogas technology in China has developed over the course of 20 years. More than eight million family biogas digesters and 800 large biogas plants had been built around the country by the end of 2000. “Energy environment projects” and “ecological homeland projects” were combined with biogas technology, agricultural production and environmental protection. By doing so, a new model of crop production and animal husbandry took shape in rural areas. The biogas project has greatly promoted ecological agriculture and the environment.

Biogas projects aim at providing a complete set of equipment that can turn organic wastes into clean biogas and efficient fertiliser by anaerobic processes. The equipment may be a simple device for family use or a large-size plant to treat agricultural waste. It can provide clean energy for everyday life, produce forage and fertiliser for agriculture, soak seeds, control insect and pest populations, increase output of plants and fruits, and improve the soil. With the popularization of biogas technology, the hygiene of the pigsty and toilet has been notably improved and the breeding of mosquitoes, flies and harmful germs prevented. As a result, the development of biogas has benefited the environment, the standard of living and economic development. It has brought about great changes in China’s rural areas. During the past years of biogas development, different models have emerged in different areas of China according to the needs of the local population.

The development of ecological courtyard models in northern rural areas began in the 1980s. This model optimizes and combines a greenhouse, pigsty, biogas digester and toilet in the farmer’s courtyard, and forms a “quaternity” system of solar energy, biogas, planting and animal husbandry. All of these interact and complement each other to form a virtually perfect mini-ecological system. At the same time it improves the environment and the economy.

The typical structure looks like this: an underground biogas digester is built under a yard that has a pigsty and toilet directly above, and a greenhouse nearby. Human and animal excreta drop directly into the biogas digester. The greenhouse uses solar energy, biogas lighting, biogas fertiliser and CO₂ from the digester. Farmers can get clean energy and safe agriculture products and by-products free, thus increasing their income several times. They also enjoy a cleaner environment.

With the development of intensive farming, large-scale planting has been advocated. Since the early 1990s, the ecological courtyard model has gradually expanded from farmers’ yards to large

Figure 10: Schematic diagram of the biogas courtyard model in northern China

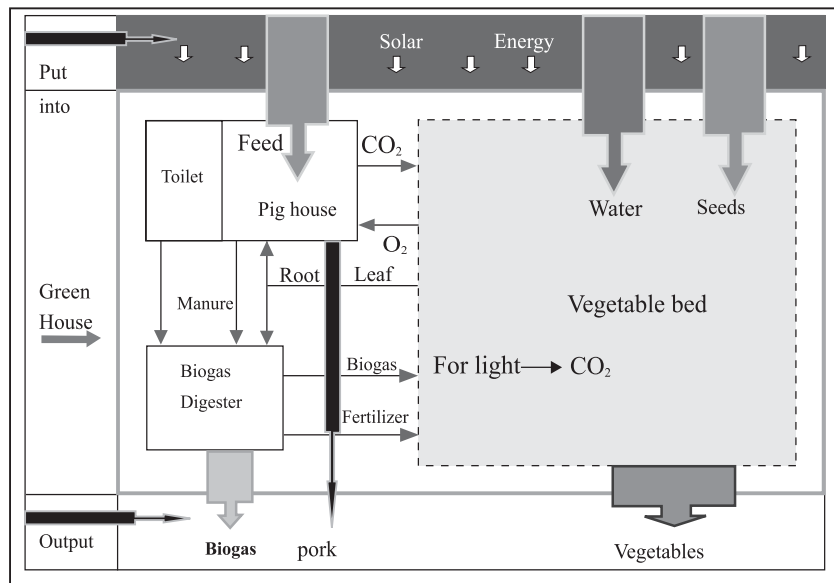

Source: Wang Mengjie, 2002.

fields. The typical unit is like this: the area of a greenhouse is about 0.5-1.0 mu (1 mu=667m²), the volume of a biogas digester is 8-12 m³, and a solar pigsty covers an area of 20 m². Its scientific and effective management ensures great benefits. In this system, human and animal excreta go directly into the digester where they are sanitized. Biogas is then used as a source of light and as fuel, which provides CO₂ for the vegetables in the greenhouse. Biogas liquid is used as a fertiliser for vegetables and fruit, and biogas residues are used as base fertiliser to improve the soil.

The pigsty and biogas digester are built in the greenhouse because the biogas digester provides heat not only for the crops, but also for the pigs. A warm environment promotes pig growth, saving farmers the cost of excess feed. Moreover, the biogas digester can easily operate throughout winter in cold areas. Another positive effect of having the pigsty with the greenhouse is that the oxygen being created by the plants is constantly being converted by the pigs back into the CO₂ required for the plants to grow. The rural courtyard ecological system provides an effective, practical, and scientific model for the development of ecological agriculture in China.

This system has distinct economic, social and environmental benefits. Compared to the conventional method, more pigs can be raised in the same amount of space. Vegetables do not need any chemical fertiliser, and their output increases by 20-30 percent. More than RMB 5,000 can be earned from a courtyard of "quaternity" (greenhouse, biogas, pigsty and toilet) every year. For example, there are 5,560 courtyards of "quaternity" in Dawa County of Liaoning Province. Annual average income is RMB 6,260. The net income from the field of "quaternity" amounts to RMB 10,000-28,000 per year. In Feitun Village of Pulandian District there are 213 fields of "quaternity", which can produce more than RMB 14,000 per mu. By the end of 1999 there are 172,000 "quaternity" in Liaoning Province. From the perspective of financial analysis or national economic analysis, investments into "quaternity" systems return big profits.

The social benefits of this model are notable. “Quaternity” can provide safe vegetables and fruits. Each unit can contribute RMB 17,000 of income and RMB 590 of tax annually. It can also stimulate development of related industries. Each unit can provide jobs for two labourers. It has also changed production and living habits of farmers in cold, northern areas, keeping them busy in the winter and allowing them to earn money year-round.

The environment has also greatly improved by biogas technologies. In the past, farmers’ courtyards tended to be dirty and disorderly. Now they are tidy, clean and hygienic. Each family has a clean pigsty and toilet. Organic wastes are processed in the biogas digester, environment pollution is prevented and the spread of disease is reduced. According to statistics, the rate of intestinal infectious disease in “quaternity” villages has decreased by 29-33 percent compared to “non-quaternity” villages. Enteritis has also decreased notably. The rate of enteritis in pigs, chicken and ducks has decreased by 72 percent, 52 percent and 82 percent, respectively. All of these are typical achievements of the system.

The soil in greenhouses can also be improved and sanitized through this system. According to tests, the porosity of the soil increased by 15 percent within three years after biogas sludge was being used as a fertiliser. Soil pH hardly changed, unlike with chemical fertilizers that cause pH levels to decrease with use. Organic matter increased by 0.98 percent within three years. When biogas sludge is used as fertiliser, soil fertility increases every year. It can also prevent soil from becoming too acidic and provide a good environment for greenhouse crop growth.

The Ecological “Pig-Biogas-Fruit” Model in Southern China⁸

The ecological “pig-biogas-fruit” model in southern China is formed by combining biogas with agricultural and ecological environmental development. The “pig-biogas-fruit” model is a project of ecological agriculture and environmental protection, which aims at developing related areas, such as animal husbandry, fruit and agriculture production and environment together. Concretely, “every family builds a biogas digester, sells two pigs per capita per year, plants one-mu fruits per capita,” which results in “a greatly improved ecological environment.” Ganzhou is a prime example. The “pig-biogas-fruit” project has improved rural environment and accelerated development in the countryside. Farmers use biogas as fuel; excreta go into the biogas digester and are fermented through anaerobic digestion; mosquitoes and flies cannot breed, and parasites and pathogen are killed in the digester. As a result, infectious diseases have decreased and the health of farmers has improved. Moreover, the whole village takes on a different look. Because farmers do not use firewood as fuel, they will no longer randomly cut down trees. In Ganzhou, a biogas digester with six cubic metres can save 25 tons of firewood every year. The “pig-biogas-fruit” project has developed on a large scale in this area, so the rate of vegetation has increased from 44 percent in 1982 to 85 percent in 1995.

2.3 Commercial Use of Large-Size Biogas Systems

2.3.1 On-Farm Biogas Systems

Biogas From Large-Scale Hog Farms⁹

Hog manure is a good raw material for anaerobic digestion because of its relatively uniform physical and chemical properties. A medium-sized adult pig produces approximately 2 kg of recoverable manure per day. This represents approximately 60 litres of biogas, which is 60 percent methane that would be produced from a technologically-poor plant. Table 1 shows the gas production potential of a 150-pound hog at a more technologically advanced plant while Table 2 illustrates the manure production of pigs at various life stages. The data can be used to estimate the total manure and potential biogas production from a hog operation, which has hogs at various levels of development.

Table 1: Potential Gas Production of Swine

	SWINE 1501bs
Gas yield cu. ft. per lb volatile solids destroyed	12
Volatile solids voided lb/day	0.7
Percent reduction of volatile solids	49
Potential gas production cu. ft. per day	4.1
Energy production rate. BTU/hr/animal	103
Available energy BTU/hr[after heating digester]	70

Source: Fulhage, Sievers, and Fischer, p. 2.

Table 2: Manure Production from Individual Hogs

Weight (kg)	Age (weeks)	Manure Production (litres/day)
4-11	3-6	1.1
23-34	9-12	3.4
18-91	8-22	5.1
80-91	20-22	9.1
Nursing sow and litter	(wean at 3 weeks)	15.6
Nursing sow and litter	(wean at 6 weeks)	19.5

Source: Agriculture Canada, Farm Buildings Handbook.

Biogas potential can also be calculated according to the amount of raw manure. Approximately 1 kg of pig dung is equivalent to 60 litres of biogas or 30 litres of biogas per day per kg weight. Table 3 compares the manure and gas production potential of cattle, hogs and poultry for the purposes of digestion.

Table 3: Manure and gas produced by one animal

Animal	Manure produced by one animal(ft ³ /day)	Additional water % of manure	Biogas produced ft ³ /day
Cow	1.5	25	50
Pig	0.2	200	7.8
Chicken	0.004	800	0.4

Source: Hazeltine and Bull, 1999, p.150.

Costs and Benefits of Methane Digestion Systems

Many economic and non-economic factors must be considered. These include the monetary costs of a methane digester and the monetary and non-monetary benefits of digesters. These issues will be treated in the following section.

Costs

The costs of establishing and running a methane digester are dependent on the specific type and size of the digester. Hog manure has an optimal retention time of 15-25 days to maintain fermentation bacteria at an adequate level. The capacity required for a hog operation digester is approximately 15 times the daily volume of manure. The average daily amount of manure produced by different animals at different life stages has been shown in Tables 1, 2, and 3. The size of the digester will be determined by these numbers. A few common costs can, however, be applied to all biogas operations. These costs are the capital and operational costs.

Table 4: Capital cost estimation of treatment units (US\$)

Equipment items	Farm size (number of pigs)				
	300	1000	2000	3000	5000
Solid/liquid separation unit	5340	11949	19037	24932	35017
Anaerobic reactors	12467	27417	43506	56968	80205
Aeration tank	3545	8072	13049	17063	23882
Polishing tank	2800	6376	10306	13476	18862
Sludge dewatering bed	2600	5460	8320	11440	16640
Total equipment cost	26752	59274	94218	123879	174606
Tax(4%)	1070	2371	3769	4955	6984
Total capital cost	27822	61645	97987	128834	181590

Source: Yang and Gan, 1998, p. 25.

Capital Cost

Capital cost of establishing a biogas plant includes interest and financing the plant, interest rate, loans, equity, etc., which are dependent on the size of the operation. To reduce capital cost digesters may be built with local construction materials to local specifications. Table 6 shows a capital cost analysis in US dollars for biogas digester facilities (in Saskatchewan, Canada) at farm size of three hundred, one thousand, two thousand, three thousand, and five thousand pigs.

Operational Cost

Acquisition of raw materials, water for mixing materials, feeding and operations of the plant, preventative and on-going maintenance, supervision, storage and disposal of the slurry, gas distribution and utilization, and administration are all different operating costs associated with running a biogas plant.

As the training of personnel can have a direct effect on the gas yields in biogas plants, management by a skilled person is necessary for an efficient and profitable biogas plant. Without proper management and the willingness to train personnel, the potential efficiency of a digester is questionable.

Table 5 shows cost estimations for digester plants, in Hawaii, in US dollars, for farms of varying sizes. This estimation includes some benefits such as gas and fertiliser production, but excludes others such as irrigation effluent. The cost of the plant is considered on a per animal basis and the break-even point is shown to be at 830 pigs.

Capital costs can be reduced for small operations through new technologies, such as the use of high-density polyethylene in place of current tank materials. The use of these technologies lowers the break-even point from 830 pigs (average weight of 77kg) to 227 pigs.

Table 5: Total cost estimation of biogas systems (Hawaii, USA)

Items	Annual Cost Balance(US\$)				
	300(pigs)	1000(pigs)	2000(pigs)	3000(pigs)	5000(pigs)
Gas production	2068	6893	13786	20679	34350
Fertilizer value of sludge (value of irrigation effluent not included)	3823	12744	25488	38232	63720
Operation and management cost	-4726	-10270	-18560	-26849	-42768
Balance	1165	9367	20714	32062	55302
Loan					
Initial capital cost	-27822	-61645	-97987	-128834	-181590
Operation period (years)	10	10	10	10	10
Annual interest (%)	6	6	6	6	6
NPW of total cost	-19248	-7296	-54468	-107142	-225433
Unit cost (US\$/pig/year)	-6.42	0.73	2.72	3.57	4.51

Source: Yang and Gan,1998, p. 26.

2.3.2 Community Biogas Installations

Community Biogas Plants Supply Rural Energy and Water¹⁰

Virtually all biogas programmes are based on family-sized biogas plants rather than community biogas plants, yet family-sized biogas plants lose significant economies of scale. The amount of biogas they are able to produce is more suited for cooking than for running an engine or generating electricity. Community biogas plants are more economical but the problems associated with them tend to be social rather than technical. They may, for example, bring about serious organizational difficulties or raise equity issues.

In addition, the low bodyweight of free-grazing bovine animals, particularly in drought-prone areas, can make the bovine waste resources inadequate to meet cooking-energy needs even when the bovine-human population ratio may seem satisfactory. In such situations, the use of community biogas plants to generate electricity is worth considering, particularly because it is an ideal fuel to run an engine that can then drive a generator and generate electricity. It is particularly useful in the context of dual-fuel (diesel and biogas) engines. It was against this background that a decentralized biogas electricity system was established and demonstrated at Pura Village (Kunigal Taluk, Tumkur District, Karnataka State, South India) as an alternative for providing rural electricity.

Figure 11: Traditional energy supply system in Pura

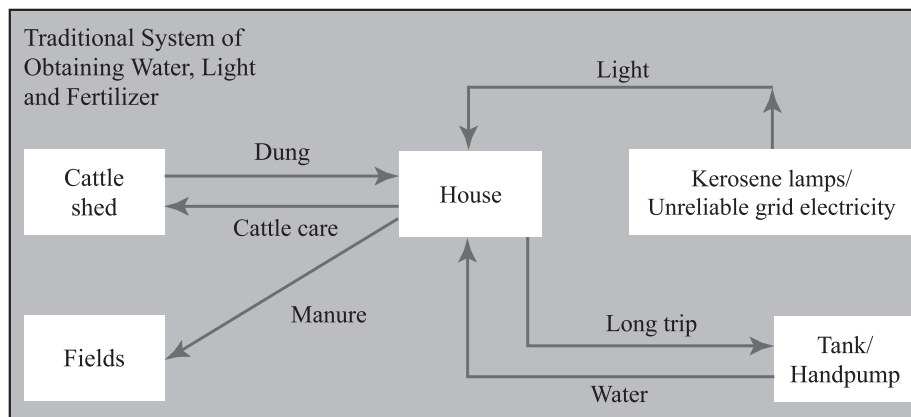

Source: Reddy, Amulya et al., 1995.

Since 1987, the traditional system (Figure 11) of obtaining water, illumination, and fertiliser in Pura Village has been replaced with a community biogas-plant electricity-generation system. This system consists of the following activities (Figure 12):

- The households deliver cattle dung to the biogas plant in the mornings (24 percent of the dung is delivered by women, 27 percent by girls, 27 percent by boys, and 22 percent by men);
- The dung delivered is weighed and recorded in the owner's passbooks and the plant's ledger books;
- Processed sludge is returned to those who want to withdraw sludge;
- The dung is mixed with water in a 1:1 ratio (by volume) and the biogas plant is charged by the dung-water mixture;

Current Situation and Recent Developments

- The resulting slurry is poured onto the sand-bed filters for filtration and production of de-watered sludge;
- Biogas is released from the plant and fed to the engine, along with the required amount of diesel, in order to start the dual-fuel engine and the electrical generator;
- Electricity is supplied for illumination of homes and for running the submersible pump that will bring water to the overhead tank;
- The biogas plants and their surroundings must be kept clean;
- The households must be visited to receive payment for electricity services and to make payments for the dung received;
- Plant records and accounts must be maintained.

Apart from the delivery of dung to the plant and the withdrawal of sludge, which are performed by the households, all activities associated with the operation of the biogas plant, electricity generation and distribution, and water supply are performed by just two village youth, who were employed by the project.

Impact of the Biogas System

When the community biogas plant electricity-generation system was introduced, the village of Pura had already been electrified by the Karnataka Electricity Board grid. In India, the mere fact that a village is electrified does not mean that individual homes within that village have electricity. In general, only 20 to 30 percent of the homes in electrified villages actually receive electricity; in Pura, 43 percent of the homes were electrified before the new system was installed. By July 1994, 59 percent of homes had grid electricity, with some having both grid and biogas; the remaining 41 percent (36 homes) all had biogas.

Figure 12: Alternative (modern) energy supply system of the Pura village

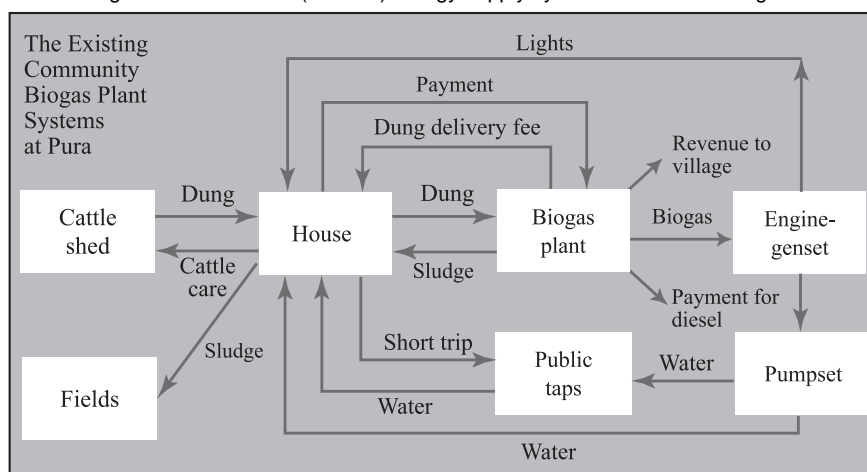

Source: Reddy, Amulya et al., 1995.

Even the steps toward limited-grid electrification that took place in Pura may not be possible soon in other villages. This is true for a number of reasons:

- Electricity has become scarce and expensive in India;
- Apart from the recent efforts to provide electricity to irrigation pumpsets, rural areas have been neglected in conventional electricity planning, e.g., in Karnataka state, only

- 20 percent of the total electricity flows to rural areas;
- The situation is aggravated by the fact that there are enormous costs and losses involved in transmission and distribution lines (e.g., transmission and distribution losses are about 21.5 percent in Karnataka);
- Electricity has become extremely unreliable in rural areas, both with regard to duration (there is frequent load-shedding) and voltage;
- Even in electrified villages, it is not accessible to most of the people.

The Technical Subsystems of the Pura Biogas-Plant System

The community biogas-plant system of Pura consists of the following subsystems:

- Biogas plants in which bovine waste is anaerobically fermented to yield biogas;
- A sand-bed filtration subsystem to filter the biogas plant slurry output and deliver filtered sludge with approximately the same moisture content as dung;
- The electricity generation subsystem;
- The electricity distribution subsystem for the electrical illumination of homes;
- The water supply subsystem.

The Long-Term Performance of Biogas Plants in Pura Village

Biogas plants are normally designed on the basis of either the minimum dung available or the maximum gas consumption that is required. Gas production depends upon the amount of cattle dung and the ambient temperature. This temperature dependence is the reason for the universal complaint that biogas plants produce very little gas in the winter, creating a need for supplemental fuels. At Pura Village, the gas production has been virtually uniform throughout the year.

The amount of dung available to the biogas plant depends upon the number of bovine animals and the fodder intake of these animals. In the case of free-grazing bovines, their fodder intake depends on the grass cover in the pasture lands, which depends on the seasonal rainfall. The dung yield varies between the seasons, meaning that the loading rate (that is, digester volume x total solids concentration) also varies. The ambient temperature also has seasonal variations. Interestingly and fortunately, the shifts from minimum to maximum and vice-versa in both dung yield and ambient temperature are gradual, and the peak of dung yield (loading rate) coincides with minimum temperature and vice versa, i.e., in summer, the temperature is highest, but the dung yield (loading rate) is lowest and in winter, the temperature is lowest, but the dung yield is highest. Earlier findings have emphasized that the response of biogas plants to these variations in loading rates, ambient temperature, etc., is slow and gradual.

Maintenance

The biogas plants require periodic maintenance to function properly. For example, the gas holders must be painted once every two years with chlorinated-rubber black paint to prevent corrosion. The material was designed to be rust-free (that is, it was primed with a non-corrosive primer followed by two coats of chlorinated rubber paint). However, in spite of corrosion-prevention measures, after five years of operation, corrosion was observed at the joint where side sheet and top sheet are welded. The electricity generation sub-system is maintained by the same two village youths responsible for operating and maintaining the biogas plants and the electricity and water sub-systems.

Administration, Organization, and Institution-Building

For community technologies to work, they require proper administrative arrangements: first, creating organizations and secondly, building them into appropriate and sustainable institutions. The key administrative arrangement contributing to success in the Pura biogas electricity generation scheme was payment of a dung delivery fee that went primarily to women. This ensured the involvement of the village women, who are the principal beneficiaries of the water supply and the electric lights.

In terms of organization, the key measure was the establishment of the Village Committee consisting of those who are leaders in traditional community activities, such as conducting festivals and dramas. This committee was responsible for overseeing the maintenance and operation of the rural energy centre, the contribution of dung, the collection of payments for the supply of biogas outputs (e.g., electric lights and water) to the home, and the formulation and execution of plans for the further development of the rural energy centre.

The Pura Community Biogas Plant is held together and sustained by the convergence of individual and collective interests. It is customary to discuss the problem of individual gain versus community interests in terms of the famous “Tragedy of the Commons” - the personal benefits that each individual/household derives from promoting the further destruction of the commons (i.e., community resource) are larger and more immediate than the personal loss from the marginal, slow, and long-term destruction of the commons.

Hence, each individual/household chooses to derive the immediate personal benefit rather than forgo it and save the commons. Experience with the factors holding together and sustaining the Pura Community Biogas Plant system appears, however, to illustrate a converse principle that may be termed the “Blessing of the Commons” - the price for not preserving the commons far outweighs whatever benefits there might be in ignoring the collective interest. The “Blessing of the Commons” is based on the coincidence of self-interest and collective interest. Thus, in the case of Pura, non-cooperation with the community biogas plant results in a heavy individual price (access to water and light is cut off by the village), and this is too great a personal loss to compensate for the minor advantage of non-cooperation with the community and non-contribution to collective interests.

2.4 Biogas for Industrial Waste and Wastewater Management

Biogas Project for Grey Water Sanitization¹¹

Biogas digesters for greywater sanitization can be used in small towns and suburban areas lacking adequate drainage systems in China. However, in cities of less than 500,000 people, greywater treatment should be separated as the treatment process takes a considerable amount of time. There are 500 such cities in China. Authorities have approved biogas technology as a practical system for greywater sanitization, making biogas important in treating water pollution and improving ecological environment.

Since the 1990s, the pace of urban growth has rapidly increased in China. In 2000, greywater has amounted to 223×10^8 cubic metres per year, while in 1995 biogas digesters in cities could only handle 1×10^8 cubic metres greywater per year.

Greywater treatment by biogas digesters has its own distinct features: separate investment; easy to raise money; local treatment; low transport cost; no need for special management; no need for energy input; and they are built underground and thus there is no need for land. Pilot projects in various places have achieved satisfactory hygienic and environmental standards. Biogas projects are an effective approach for separate treatment of greywater in urban areas.

It costs less to treat greywater in biogas digesters than conventional treatments. Biogas digesters provide noticeable help in preventing environmental pollution, especially in controlling infectious disease. Furthermore, treated water can be used to irrigate greenbelts, clean streets, and wash cars to ease serious water shortages in the country. The development of biogas digesters for greywater sanitization should correspond with city planning. The biogas digesters for greywater sanitization in towns of China have drawn attention for technical cooperation with other developing countries.

Resource Recovery and Utilisation of Bio-organic Municipal Waste¹²

The Sino-German cooperation project on “Resource Recovery and Utilisation of Bio-organic Municipal Waste,” (RRU-BMW) in Shenyang, China is aiming at utilizing appropriate Anaerobic Digestion (AD) technologies for “clean renewable energy” production and to produce “clean compost” for land application in China. The project provides information about the attitude and behaviour of the population towards participation in source separation of BMW, and it analyses different ways of BMW collection and carries out field- and lab-tests to assess quantities, qualities, biodegradability and pollution levels of biogas and compost. BMW will be collected in four different pilot areas and the investigations include the utilisation of remaining waste (RMW) with an increased calorific value.

Biogas from BMW and rural wastes can be one of the major sources of renewable energy as demonstrated in some European countries, such as Austria, Denmark, Sweden, Finland, and the Netherlands. Austria operates four municipal-level central technical biogas plants, producing about six million m^3 of biogas annually (approximately two percent of total biogas produced in Austria). One of these plants is the biotechnological treatment plant in Wels, where the following feedstock is treated: 1) yard waste and sewage sludge composting and 2) 10,000 tons per annum (t/a) of PSS-BMW (Primary Source Separation). Together, the two groups generate one million m^3 of biogas annually, in addition to approximately 5,000 tons of “clean” compost.

Wels is a medium-sized city in Austria, which applied an advanced integrated-waste treatment concept in 1996 to treat 185,000 tons of wastes annually. The facilities, especially the waste incineration plant, with its five-step flue gas-cleaning system, meet the highest environmental protection standards. Of the input material, 39 percent is recovered as secondary raw materials such as paper, metals, wood, construction waste and compost, and 36 million kW electric power is provided from waste incineration and biogas production. The biogas technology is based on a

2-step, liquid mesophilic anaerobic fermentation in a flow-trough, biogas-mixed, vertical enamelled-steel fermenter, supplied by Linde KCA, Germany. The other BMW AD plants in Austria are operated by Dranco Technology from OWS Belgium (20,000 t/a) in Salzburg and Kompogas Technology from Switzerland in Dornbirn.

Municipal Solid Wastes (MSW) can be used for biogas production if the appropriate technology is applied. The non-bioorganic content of MSW will reduce the specific gas yield and the demand for more mechanical processing is considerably higher. So far, it is already well-known throughout China that compost from MSW cannot meet the requirements for “clean compost” suitable for farming (food production) and landscaping, due to sustainable soil protection. The technologies to generate the biogas from MSW are available. In the proposed Shenyang BMW AD plant, MSW treatment will not be recommended in order to fall in with one of the main objectives, ‘to produce clean compost,’ as the second valuable output fraction.

The feasibility of further introductions of anaerobic digestion of urban bioorganic wastes will also depend on the availability of economic instruments such as the introduction of “waste fees,” ongoing since 2002; the planned allocation of two percent of China’s GDP for environmental protection; the success of applying the CDM mechanism and emission trading; and the enforcement of supporting policies on renewable energy.

2.5 Anaerobic Digestion as Part of Ecological Sanitation

Biogas Manure as Input to Sustainable Agriculture¹³

The major bottleneck faced by the biogas technology in its dissemination and integration is the unfavourable results of a cost-benefit analysis when conducted in the conventional manner. For example, a study of biogas plants in India concludes that in terms of quantifiable monetary (“real economic”) benefits and costs, the biogas plants programme results in annual monetary savings of INR 128 million (USD 2.75 million), but with an annual cost of INR 150 million (USD 3.2 million). However, if the analysis took into account the conservation of trees, and external factors such as pollution, improvement in the health of women, use of biogas slurry as manure and its replacement of energy intensive chemical fertilisers, improvement of soil quality by the use of biogas slurry application etc., then the scenario would provide a more complete picture.

It is in this context that the promotion of Biogas Manure (BgM)-based sustainable farming technologies becomes important in the spread of biogas technology. The digested slurry that comes out of the biogas plant is more important than the gas itself, which is used for cooking purposes.

Biogas Manure (BgM) is a by-product obtained from the biogas plant after the digestion of dung or other biomass for the generation of methane rich gas. BgM supplies essential nutrients, enhances water holding capacity and soil aeration, accelerates root growth, and inhibits weed seed germination.

Apart from its advantages over chemical fertilisers, BgM has proven superior in its nutrient content with respect to other manures as well. The fermentation process reduces the carbon to nitrogen ratio by removing some of the carbon and thereby increasing the fertilizing effect.

Biogas slurry can also be used as a pesticide that carries none of the harmful effects of chemical pesticides. Experiments have shown that BgM can control a nematode attack on a tomato plant. The effect of biogas slurry application on the severity of a root-knot nematode, *Meloidogyne incognita*, attack on a tomato plant was tested in the greenhouse. The plants irrigated with biogas slurry put up more vegetative growth and tended to flower and fruit much earlier than did those of the control. It was also observed that the nematode population in the soil and the severity of the nematode attack also decreased as a result.

3. The Application of CDM to Biogas Technology

3.1 Potentials and Constraints of Integrated Biogas Systems¹⁴

In spite of the multitude of socio-economic and environmental benefits offered by the Integrated Biogas Systems (IBS) (see box below), their scaling up as an intervention for sustainable livelihood and poverty alleviation programmes around the world has been rather disappointing, with the exception of a few East Asian countries (China, India, Bangladesh and Nepal). Barriers to the “mainstreaming” of the pilot biogas projects have been associated with the lack of an institutional-enabling policy framework, as well as technical and human capacity. Whether CDM could provide a timely opportunity for leveraging and strengthening of the institutional, policy, technical and human capacity is the subject of many studies.

IBS offers a clean, low-carbon technology for the efficient management and conversion of agro-industrial wastes into a clean, renewable biogas and fertiliser source. The CDM IBS project has the potential to promote sustainable livelihood development (protein source, clean biogas, organic fertiliser for food production) as well as for tackling local (land, air and water) and global pollution (reduce methane and nitrous oxide emission).

Box 1: The potential of IBS in rehabilitating degraded land and meeting the MDGs

Continual unsustainable farming practices relying upon heavy machinery (ploughing, cultivator) and reliance upon expensive inputs (inorganic fertilizer and pesticides) have caused serious land degradation of a village in the province of Shanxi, China. For many years, no crops could be grown on this degraded low fertility sandy land. However, with the introduction of the 4-in-1 Integrated Biogas System (IBS - for the conversion of pig and human wastes into clean biogas) into this village using loans from Asia Development Bank (ADB), the well being of the whole village was transformed. Not only has the IBS been able to provide clean biogas for cooking, lighting and hot water for the households but the availability of free liquid fertilizer rich in nutrients and organic matter was able to restore the fertility of the once degraded sandy land for the cultivation of the valuable lotus root crops. This has not only improved the health and well being of the villagers but the economy of the whole village was transformed and lifted the villagers out of poverty.

However, except for some South and East Asian countries (China, India, Nepal and Bangladesh), many small- and large-scale biogas projects have not yet been able to move beyond the pilot phase. The barriers to their scaling-up and “mainstreaming” has been recognized as the following.

Technical (Biogas and Animal Husbandry) Competence

- Lack of competent technicians and funds to mend repairs;

The Application of CDM to Biogas Technology

- Poor material quality leading to corrosion, breakdown and leakages;
- Lack of equipment supplies and spare parts;
- Insufficient and poor quality feedstock for the digester and low temperature leading to low biogas yield;
- Poor animal husbandry due to poor feed-quality and animal health and high emission of enteric methane

Institutional and Policy Barriers

- Sectoral, top-down, compartmentalized-approach in the delivery mechanism leading to lack of follow-up support services and ownership of projects;
- Lack of governmental, institutional and local programmes focusing on “technology fix” (like the Integrated Biogas System);
- Lack of sound fiscal policy to provide incentive (taxation, capital allowance) to attract investment in biogas technology.

Table 6: Role of IBS in meeting the MDGs by strengthening the five capitals

Millennium Development Goals	Integrated Biogas System
Goal One: Eradicate extreme poverty and hunger: halve the proportion of people whose income is less than a \$1 a day	Provide sustainable livelihood and income from diversified income generating activities to strengthen the Human capital . Provide extra employment opportunity
Goal Two: Achieve universal primary education	Clean biogas lighting will allow more study time during the night to strengthen the Human capital
Goal Three: Promote gender equality and empower women: eliminate gender disparity at all levels of education	Create wealth and health for women and children to strengthen their Social capital . As 70% of the rural women are responsible for looking after the livestock, the ownership of digester will boost the women's confidence.
Goal Four: Reduce child mortality: cut the under five mortality rate by two thirds	Improve mother and children health through improved healthy organic food to strengthen the Human capital
Goal Five: Improve maternal health: reduce by three quarters the maternal mortality rate	Improve women health through cleaner biofuel and less time required for firewood and water collection thus strengthening the Human capital
Goal Six: Combat HIV/AIDS, malaria and other diseases: halt and begin to reverse the spread of major diseases	Potential to intercrop Chinese wormwood and healthy food crop using the organic fertilizer to improve diet and medicine for malaria thus building up the Human capital
Goal Seven: Ensure environmental sustainability	Access to good income, clean energy and fertilizer will empower the farmers to take care of the environment and manage their resources efficiently (Clean air, land and water) thus strengthening the Natural capital
Goal Eight: Develop a global partnership for development: encourage countries, poor and rich, to communicate and work with each other to end poverty	Through CDM instruments linking CERs buyers with farmers and poor community to strengthen the Financial and Technical/ Manufacturing capital

Barriers to Social and Entrepreneurship Development

- Lack of public awareness and gender bias against women and marginalized group of participants;
- Lack of success with entrepreneurial business model for scaling-up biogas system;
- Cultural taboos prevent the use of animals and humans as feedstock for clean biogas and fertiliser;
- Incorrectly placing the primary focus on dissemination rather than commercialization modality for the “mainstream”;
- Failed breeds and disappointment with loss of technology.

Barriers to Financing

- Lack of access to affordable credits due to continual under-funding within the agriculture sector;
- Failure to pay back loans due to underemployment;
- Lack of a creative financial modality for the mainstreaming of the pilot biogas project (pros and cons of term loan, leasing and equity financing).

3.2 The Community Development Carbon Fund¹⁵

As of April 2003, the World Bank's Community Development Carbon Fund (CDCF), which concentrated on small-scale projects, had received about 30 project ideas representing projects between 0.6 and 1.2 million metric tons of carbon equivalents (MtCO₂e) of total reductions. Finland is expected to sign contracts to purchase about 500,000 tCO₂e of Certified Emission Reductions (CERs)² from three or four small-scale projects at prices from EURO 2.10 to EURO 6.30 per tCO₂e. Those prices are comparable to the prices for CERs from larger CDM projects, suggesting that the simplified methodologies reduce the transaction costs, and keep small-scale projects competitive in the market.

Included in the CDCF portfolio is the biogas project to develop 162,000 digesters to generate biogas to replace kerosene and firewood use in Nepal. It is expected to generate 5.3 MtCO₂e for ten years with delivery starting in 2005; CDCF has committed to purchase 1 MtCO₂e. This project hopes to generate 15,000 new rural workers per year.

For any projects to be eligible for CDM transaction, the following checklists must be observed and applied.

A. Host Country Eligibility

The proposed CDM project activity has to be implemented in a host country that:

- Is a Party to the United Nations Framework Convention on Climate Change (UNFCCC);

² "Certified Emission Reductions" or "CERs" means a unit issued pursuant to Article 12 of the Kyoto Protocol as well as all other relevant International UNFCCC/Kyoto Protocol Rules and is equal to 1 metric ton of Carbon(or CO₂) equivalents (CO₂e), calculated in accordance with the International UNFCCC/Kyoto Protocol Rules.

The Application of CDM to Biogas Technology

- Has ratified the Kyoto Protocol;
- Has established a Designated National Authority (DNA) or a Focal Point that is delegated to coordinate and approve local CDM project proposals;
- Has clear sustainable development criteria in place;
- Has clear legal framework on CER ownership, project developer status;
- Has clear fiscal policy on taxation and ownership of CER and bankability of CER;
- Has easy access to this information, e.g., website.

B. CDM Project Eligibility

All proposed CDM Project activities must:

- Have the potential to comply with the UNFCCC CDM project activities' validation, registration and verification guidelines (see <http://cdm.unfccc.int/> for more details);
- Generate CERs, at least during the 2008-2012 commitment period;
- Have baseline and monitoring methodologies that are being reviewed or have already been approved by the CDM Executive Board.

C. Project Sponsor/Developer Eligibility

The project sponsor and/or the project developer of the CDM project:

- Must have a proven track record in the development of similar project activities;
- Must have the financial capability and competence to realize the project activity as outlined in the project documents;
- Must be an accredited business organization in the host country and have good legal standing.

D. Types of Financial Options

The price of the CERs would be determined by risk-taking shown by the project developer and owner. Higher prices would be allocated to projects that have been registered whereas those with validation risk will fetch lower prices. The issues involved in the negotiation of the ERPA may consider the following types of financing options for the purchase of CERs.

Payment on Delivery

CERs purchasers would consider a "Payment on Delivery" ERPA (Emission Reduction Purchase Agreement) for the direct purchase of CERs from a project activity whereby the buyer would pay on the delivery of CERs. A payment on delivery purchase contract is defined by which the buyer and its counter-party would agree on the pre-negotiated price, volume, and delivery schedule of CERs to be delivered into a dedicated buyer's account upon the issuance of the CERs by the CDM Executive Board. Selling of the registered CERs will fetch the highest price as the project developer and owner is absorbing all of the upfront project risks.

Pre-paid Purchase Contract

The CERs buyers would be willing to advance funds incrementally into a CDM project activity based upon the completion of specific, pre-negotiated project milestones, such as achieving CDM project validation, host country approval, registration and issuance of CERs.

The exact terms and conditions of the advanced payments for the purchase of CERs would be documented in an ERPA. In order to qualify for a pre-paid structure, the CDM project has to meet the following criteria:

- The counter-party must provide satisfactory performance guarantees and demonstrate satisfactory credit quality or credit enhancement (such as a performance letter of credit) to support their delivery obligation;
- The buyer will receive the first rights of creation to any CERs generated by the project activity.

Debt Financing CDM Projects

The CERs buyers would consider debt financing CDM project activities in the form of either senior or subordinated debt under the following conditions:

- At least a portion of project debt service would be paid in-kind in CERs;
- The seller must provide liquidated damages (with related credit support) for debt service obligations which are paid in-kind (CERs);
- The debt financing must be secured by a security interest in the project or supported by other collaterals, such as an acceptable surety or equivalent guarantee in the amount of buyer's financing;
- The project must conform to customary project finance/credit criteria, such as sponsor representations, conditions, precedents, covenants or pledges.

4. Lessons Learned and Best Practices¹⁶

4.1 Barriers in Developing CDM Projects¹⁷

The Kyoto Protocol became effective on 16 Feb 2005, binding the 38 industrialized countries listed in Annex 1 to the UNFCCC to reduce GHG emission by 5.2 percent to that of 1990 levels. Market-based mechanisms were developed for the realization of these national commitments. Clean Development Mechanism (CDM) is one of the three flexible strategies enshrined under the Kyoto Protocol that could offer a timely opportunity to overcome the above barriers by strengthening the institutional, technical and human capacity in the host country. The following discussions seek to understand how CDM could be used effectively for leveraging the mainstreaming of IBS as development tools for sustainable livelihoods and rural poverty alleviation for achieving the Millennium Development Goals (MDGs).

The following sections highlight the barriers involved in developing large- and small-scale biogas projects and how risks could be minimized in order to reduce the transaction cost to ensure strong carbon integrity. In order to attract premium CDM investors, the host country must exhibit strong political leadership in the setting up of functional and effective CDM institutions within a clear and transparent policy framework. Strengthening this capacity will not only reduce approval time and transaction costs but also help to minimize implementation risks for project owners, developers and investors.

Country Commitment

There is still some uncertainty and reluctance by Asian countries to take advantage of the CDM instruments. This lack of commitment by the governments has caused regional imbalances in the number of projects submitted, which are dominated by Brazil and India. A lack of competent national staff and clear guidelines not only delays the project approval process, but also increases transaction costs and often deters and discourages potential investors. There is also a need to strengthen the communication between national and local CDM entities in order to ensure a smooth CDM transaction and implementation.

Institutional Barriers

In order to be eligible for a CDM project, the host country must:

- Be a Party to the United Nations Framework Convention on Climate Change (UNFCCC);
- Have ratified the Kyoto Protocol;
- Have established a Designated National Authority (DNA) or a Focal Point that is delegated to coordinate and approve local CDM project proposals.

The host country must clearly outline their taxation laws, property and CER ownership rules, and rules regarding who should be the lead project developer. For example, the DNA in China stipulates that a local company with 51 percent majority must be the lead project developer. China also

uses fiscal taxation laws to deter projects that do not substantively contribute highly to national sustainable development. National staff must be well-trained to handle biogas projects that will attract potential investors. A high tax on CER will deter investments; given the high sustainable development component, it is proposed that biogas should not be taxed at all. There must be clear CER ownership rules.

There is also the need for capacity building of NGOs. In order to encourage full participation by local stakeholders, local NGOs could be provided with training on CDM concepts and applications, particularly for less CDM-literate countries.

Financial Barriers

- Transaction cost: High transaction cost has been the main deterrence for developing small-scale projects. Table 10 illustrates the difference in transaction costs between normal- and small-scale CDM project.
- Initial investment capital: Lack of initial investment capital for project start has deterred the successful implementation of any CDM project.
- Subsidy: China and Nepal have relied on governmental subsidies of up to 30 percent of capital cost to spearhead the biogas project. It is important that subsidies do not distort market forces which could lead to unhealthy competition.
- Incentive: Providing attractive fiscal incentive could attract the private sector and local financial institution to be involved in CDM projects. Providing favourable or guaranteed feed-in tariffs for selling to on-grid electricity generated from biogas could provide an attractive incentive for investors.
- Capacity building for financial institutions: In order to develop and create financial modality to support CDM development, national financial institutions must be well-trained in assessing CDM upfront or equity loan applications efficiently.

Technical and Managerial Barriers

- Competent technicians: Lack of competent technicians in providing timely and cost-effective repair will put the project at risk of not meeting projected CERs targets.
- Strong support services: Ability to strengthen the host country's technical, managerial, and entrepreneurial capacity to reduce project risks so that the CERs could be delivered as contracted. Building materials, equipment and spare parts must be of high-quality and certified to ensure minimum breakdown and downtime.
- Marketing strategies: Marketing to recruit new participants and screen out weak participants early in the selection process. Campaigns must be effective in penetrating a wide audience to the benefit of CDM and biogas system.

Social Barriers

- Cultural taboos: In some cultures, the use and handling of animal and human wastes as energy and fertiliser source can be regarded as offensive. Education, training, and study tours could help to explain and gain community support for biogas projects.
- Female participation: Special efforts must be made to ensure that women are able to take part in CDM projects.

The CDM project cycle activities in comparison with conventional project development are shown in Figure 13. It is clear that preparing and developing CDM is complex and can be confusing. The challenges are in ensuring the smooth flow through the cycle. Hindrances to this flow will add time and resources to the project, as well as increasing transaction costs.

Figure 13: CDM project cycle compared with conventional project development

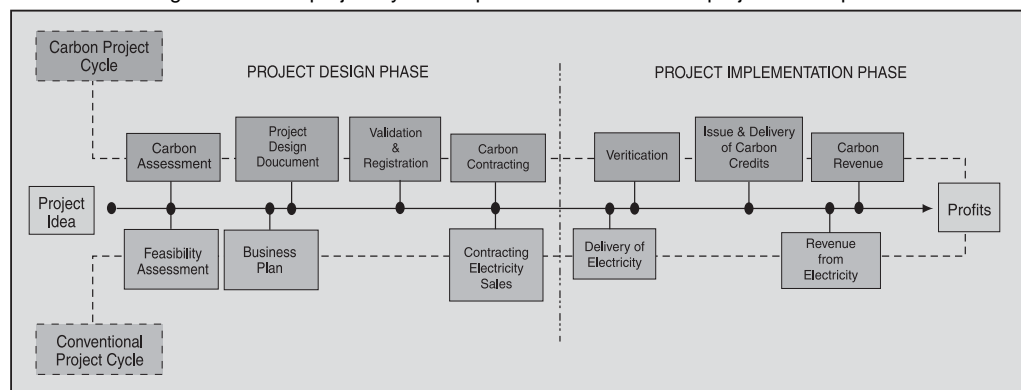

Source: EcoSecurities.

Table 7: Number of CDM projects and CERs generated

	CDM Projects					
	Number	%	CERs/yr (000)	%	Accumated CERs by 2012 (000)	%
Biomass energy	73	28	3,531	7	31,032	8
Hydro	58	22	3,202	6	24,679	7
Landfill gas	32	12	8,574	17	69,901	19
Agriculture	32	12	2,554	5	19,770	5
Wind	17	6	1,872	4	13,611	4
EE Industry	15	6	418	1	3,543	1
Biogas	7	3	471	1	4,125	1
Fossil fuel switch	9	3	370	1	3,061	1
HFCs	4	2	12,375	24	97,425	26
Geothermal	3	1	772	2	5,979	2
EE Household	3	1	42	0	215	0
Solar	3	1	44	0	269	0
N ₂ O	2	1	15,108	30	90,667	24
Fugitive	2	1	912	2	9,396	3
Tidal	1	0	311	1	1,087	0
Transport	1	0	7	0	59	0
Energy distribution	1	0	15	0	213	0
Total	263	100	50,577	100	375,032	100
Renewables	162	62	10,203	20	80,782	22
EE	20	8	481	1	4,030	1
Fuel switch	9	3	370	1	3,061	1
CH ₄ reduction	66	25	12,040	24	99,067	26
HFC & N ₂ O reduction	6	2	27,483	54	188,092	50

Source: Jason Yapp, 2005.

Since the Kyoto Protocol came into force on 16 Feb 2005, there has been an increase in the number of CDM projects submitted for validation. To date, there are 263 CDM projects with more than half (54 percent) submitted by the large HFC and N₂O projects which have low sustainable development components. Agriculture projects with high SD components only account for five percent of its 32 projects with an annual CERs of 2.5 MtCO₂e and cumulative 19.8 MtCO₂e to 2012 (Table 7).

The current CDM agriculture landscape is dominated by large-scale projects for treating swine wastes in Latin America. AgCert International PLC, who has developed the AM16 methodology has submitted 20 projects for validation with cumulative CERs of 13.1 MtCO₂e for the treatment of swine wastes in Brazil, monitoring and verification, AgCert's business model involves Build, Operate and Transfer (BOT) for ten years.

Agrosuper, using the AM6 methodology, has focused on Chile and submitted six Project Design Documents (PDD) with cumulative CERs of 5.8 MtCO₂e. Price Waterhouse Coopers is developing a CDM project in Mexico worth cumulative 127,000 tCO₂e by 2012.

In order to reduce transaction costs, the CDM Executive Board has allowed small-scale projects to use their simplified methodology for fast-tracking the baseline, validation, registration, verification and monitoring procedures. So far, three CDM biogas projects have made use of this provision.

4.2 Main Issues for Large Scale Biogas Projects¹⁸

Overall, there have been fewer problems encountered in developing large-scale biogas projects given their high viability through the bundling of 6 to 15 project sites into one PDD in order to reduce transaction costs. The baseline and monitoring methodologies are quite straightforward and well-tested. For large-scale projects, the main challenge is to generate a large enough CER, in addition to the verification of the measured data compared with the submitted data. In the case of China, the main issues are lower potential CERs that could be generated from pig farms due to lower volatile solids in the wastewater caused by solid separation. The solids are collected by farmers for use as organic fertiliser. The high-quality feedstuff and the superior genetic stock used in the Chinese farms could also lead to a lower CERs. The insistence that the project developer must be a local entity with 51 percent majority share and possible taxation on CERs puts China in a different position than those of the CDM policy in Latin America.

Temperature regimentation will determine the type of anaerobic process that could be used, as colder climates with lower winter temperatures will require some degree of heating to maintain a temperature of 37°C. Locations where ground temperatures fall below 37°C will have to bear increased project equity costs. For warmer climates, an ambient covered lagoon will be the cheapest anaerobic digestion technology.

Additionality Test

The "additionality test" is a tool for the development of large-scale biogas for pig farms and is depicted in Figure 14. For the large-scale project, additionality is based on investment additionality

where the BAU scenarios without the CERs will not take place because of low Internal Rate of Return (IRR) and Net Present Value (NPV). Most PDDs argue that without CERs, many of the anaerobic process technologies will not be implemented because of low NPV/IRR.

Table 8: Large-scale agricultural CDM projects

Approved PDD	Host Country	PDD Developer	AD Technology	ktCO ₂ e /Yr	Crediting Period (yrs)	Total Cumulative ktCO ₂ e until 2012
19 PDDs (AM16)	Brazil, Mexico	AgCort	Ambient Temperature Covered lagoon	1,862	10	13,755
6 PDDs (AM6)	Chile	Agrosuper	Temperature controlled AD	673	7	5,837
1 PDD (AM6)	Brazil	PriceWaterhouse Coopers	Covered lagoon	24	10	218
Contribution to sustainable development	<ul style="list-style-type: none"> • Mitigate GHG emission • Clean air and water • Clean energy • Create new employment 					
Main issues	<ul style="list-style-type: none"> • Call for a consolidated methodology using mass balance rather than animal population for simpler and cheaper monitoring and verification methodology; • Existing monitoring system required sound and efficient data management system; • Solid separation in some baseline, e.g., China may lead to low volatile solids and hence low CERs; • Temperature controlled AD for colder climate; • Feedstuff quality and genetic stocks may affect CER generated; • Bundling criteria - how many sites could be bundled into 1 PDD; • Project developer must be local entity, e.g., in China local entity hold 51% majority share; • Verification of submitted data (30% down on what was submitted); • pricing and taxation on CERs; • Uncertainty for post-2012 negotiation. 					
Additionality test	<ul style="list-style-type: none"> • Low IRR without CERs • Anaerobic lagoon - cheap to use and maintain • No need to capture methane 					

Source: Jason Yapp, 2005.

4.3 Main Issues for Medium- and Small-Scale Biogas Project¹⁹

Inflexible Bundling Rules of the Simplified Small-Scale Methodology

The CDM Executive Board (EB) has approved simplified baseline and monitoring methodologies for small-scale projects with a capacity of less than 15 MW, annual energy production of less than 15 GWh, or annual emissions and emission reductions of less than 15,000 tCO₂e. These simplified methodologies should reduce the transaction costs of registering a small project significantly. Small projects may also be “bundled” up to the maximum size for a small-scale project for validation, registration and verification in order to further reduce transaction costs.

Figure 14: Flowchart of testing additionality of large-scale CDM projects

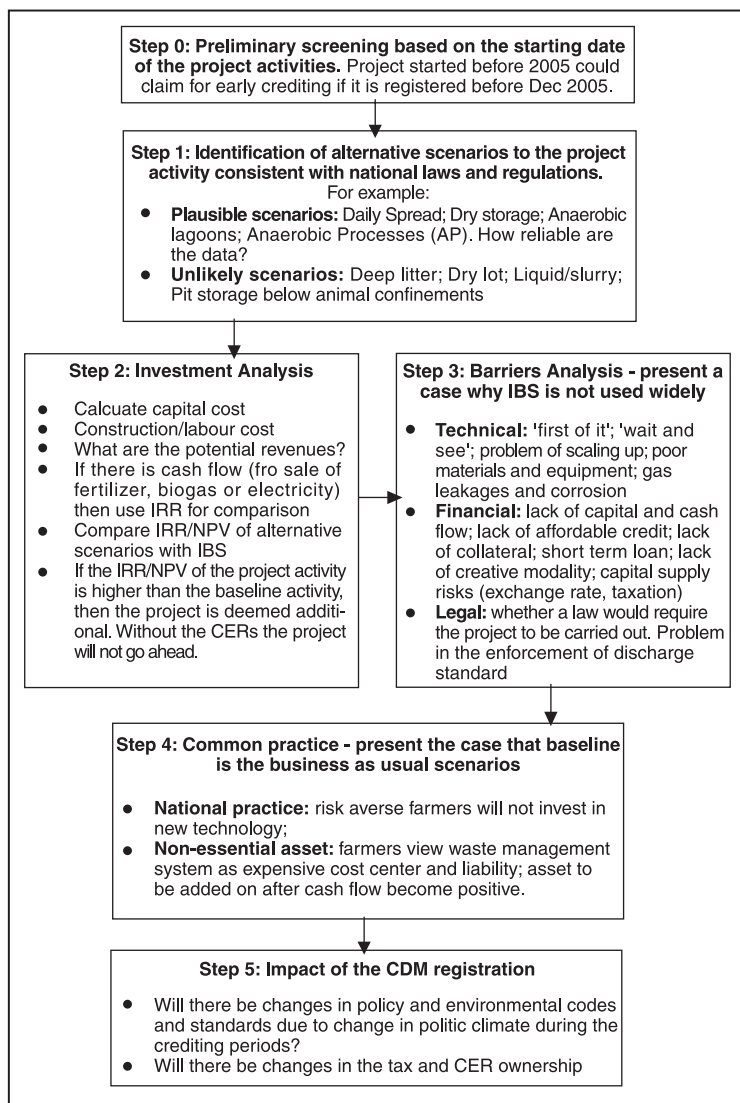

Source: Jason Yapp, 2005.

The viability of any small-scale CDM projects relies heavily upon the creativity of the project developer to reduce the high transaction cost by capitalizing on the economies of scale. Unfortunately, the rules governing the ability to bundle projects are not yet clear. Instead of making the rules more flexible so that the poor host country could reap the benefits of CDM projects, EB seems to be further restricting the bundling rules. As of July 2005, EB released the latest rulings:

- Project activities wishing to be bundled shall indicate as of the request for registration that they will be bundled;
- Once a project activity becomes part of a bundle it shall not be de-bundled, i.e. project activities that are bundled at the registration should remain part of the bundle;
- Composition of bundles shall not change over time (i.e. the submission of projects to be used in a bundle shall be made at the same time, i.e. project activities cannot be substituted for one another later on);

- All project activities in the bundle shall have the same credit period.

Moreover, although the Executive Board did not make an explicit decision, it seems quite clear that the total size of a bundle of project activities cannot exceed the limit set for small-scale CDM projects²⁰. If formally agreed, this would mean that the size of a bundle should comply with the following rules:

- Renewable energy project activities with a maximum output capacity equivalent of up to 15 MW (or an appropriate equivalent);
- Energy efficiency improvement project activities which reduce energy consumption, on the supply and/or demand side, by up to the equivalent of 15 GW/hour per year;
- Other project activities that both reduce anthropogenic emissions by source and emit less than 15 kt of carbon dioxide equivalent per year.

The ability to aggregate various small-scale projects into a larger single PDD will help to reduce the transaction cost and improve the management and monitoring strategies. There will be a need for the creation of an intermediary agent (IA) for the management of the whole IBS programme, where new participants can be added when required. The role of the IA will be:

- Work as project developer in preparation, implementation, and monitoring and evaluation of projects.

Table 9: Medium and small-scale agriculture CDM projects

Approved PDD	Host Country	PDD Developer	AD Technology	KtCO ₂ e/yr	Credit Period (years)	Total Cumulative (KtCO ₂ e) until 2012
1 PDD bundled for 20 farms	Mexico	AgCert	Ambient temperature covered lagoon	21	10	167
6 individual PDDs	Philippines	2E Carbon Access	Ambient temperature covered lagoon	17	7	126
1 PDD	India	Factor Consulting	5,500 x 2m ³	27	7	189
No PDD has been submitted for the CDCF's Nepal project	Nepal	CDCF	100,000			4.5
Contribution to Sustainable Development	<ul style="list-style-type: none"> • Mitigate GHG emission • Clean air and water • Clean energy • Create new employment 					
Main issues	<ul style="list-style-type: none"> • High transaction costs due to 15MW - force to split into small project, 1 PDD with 6,500 and cost US\$ 4.2 million for 100,000 units 					
Additionality test	<ul style="list-style-type: none"> • Replacement of non-renewable firewood source - how to argue that the project activity will replace non-renewable firewood source, what are the proof, negative incentive argument for sectoral policy approach rather than project-based approach • Unable to raise the initial capital required - CERs could help to finance the project • Although there is national policy to push for biogas digester in China and India, it is argued that existing LPG (6 times) or subsidized kerosene burner is cheaper than biogas digester - targeted for poor family who cannot afford the digester without CERs • Continue to use dirty fuel • Replace cesspool anaerobic lagoon - cheap to use and maintain • No need to capture methane 					

Source: Jason Yapp, 2005.

- Register new participants
- Provide good practice strategies
- Provide training, support and marketing services
- Promote the IBS programme to new stakeholders
- Manage the CER fund
- Negotiate the CER price

Biogas Sector Partnership (BSP)

Nepal seeks to install 162,000 IBS (2m³) across Nepal with a capacity of 2kW each (Table 10). If the simplified methodology is to follow, then each PDD must be less than 15MW. The BSP-Nepal Programme would then need to split into 31 PDDs of 6,500 IBS. It means that the transaction costs would amount to an extra US\$ 3 million for the submission of 31 PDDs compared to only submitting 1 PDD at US\$ 58,500. Given the above cost estimates, it is likely that the development of the 31 PDDs would take much more time to complete and will result in the loss of potential credits. Recruitment of new participants would lead to the loss of the previous credit period. This inflexibility will place unnecessary heavy burdens upon the host country with scant resources, and will deprive the poor of the multifaceted benefits offered by IBS.

Table 10: Transaction costs for normal and small-scale CDM project (US dollars)

	Normal scale (average)	Small-scale (average)	Cost reduction [%]	31PDDs
Upfront				
1. Project preparation and review	71,000	28,400	60	880,400
2. Project Design Document	9,000	4,800	47	148,800
3. Validation	24,000	10,800	55	334,800
4. Appraisal phase	12,000	6,000	50	186,000
5. Initial verification (start-up)	20,000	3,800	81	117,800
5. Initial verification (start-up)	6,000	3,000	50	93,000
Operation				
6. Periodic monitoring	132,000	30,000	77	930,000
7. Verification and certification (yearly)	72,000	12,000	83	372,000
7. Verification and certification (yearly)	60,000	18,000	70	558,000
Total transaction costs	203,000	58,400	71	3,620,800

Source: Bhardwaj et al., 2004.

This shows the need to call the CDM Executive Board to task by making the small-scale methodology more flexible so that aggregation can be based on the district baseline or regional baseline as a means to reduce the transaction costs further.

Non-Sustainable Forestry

The main issues in developing a small-scale CDM will be the definition of harvesting firewood from non-sustainable forestry. If the host country already has a deforestation policy in place, then it would be difficult to argue for emissions coming from non-sustainable sources. As can be seen, the calculation of the proportion of non-sustainable forestry sources remains a challenge.

Biogas Development Programme as a Common Practice

Another issue that must be addressed is that of countries in which a vibrant biogas development programme already exists, as is the case in Nepal, India, and China. How will additionality tests benefit these countries? If this is already a common practice for the host country, how will an additionality test with the CDM project improve programmes of the host country?

Sectoral Approach

In order to overcome the problems related to project-based baseline associated with negative incentive, it is proposed that a sectoral approach be developed for the agricultural sector in mitigating GHG emission. Each host country could be allocated a national baseline target for the agricultural sector which, in turn, could be sub-divided into smaller regional or district baselines. The CERs price could then be negotiated with potential buyers.

There has been much criticism in the type of CDM projects being registered, which tend to be biased towards projects with low abatement costs and low sustainable development (SD) integrity. IBS presents CDM projects with high SD integrity and large, local benefits. IBS CDM would fit the sectoral-based approach for overcoming the additionality test and negative incentive problem faced by current CDM procedures. A policy-based CDM in the agriculture sector would entail project activities undertaken with this policy rather than having to avoid designing policy that favours cleaner technology.

The host country with the awarded CERs could distribute them either as tax incentives, subsidies or other fiscal instruments. The government policy on capturing and utilization of methane and nitrous oxide, deforestation policy, clean water act, would become the project itself, turning additionality tests on its head. The sectoral-based project will prevent host countries from shying away from climate-protection strategies for fear of CDM ineligibility. On the contrary, the host country should be rewarded for creative and innovative climate change strategies to bring multi-faceted benefits to local stakeholders. Technical capacity would be easier to focus and build up. A national biogas working group could be set up to develop agricultural sector-based CDM for maximum SD integrity. Annex 1 could help to build up capacity in exchange for CERs. The baseline targets could be allocated on the basis of GDP per capita to address equity issues. This is a follow-up activity that merits further investigation with possible presentation at the COP11(11st session of Conference of the Parties to the UNFCCC) in Montreal to muster international support. This is being tested for the CDM transport in Chile and CDM energy efficiency project in Ghana.

Monitoring

In order to reduce the transaction cost, most of the monitoring plan shown in Table 11 involved using the sales service contract as the main contact point. The monitoring plan entails recording the number of digesters that have been installed and as well as those still in operation every six months. In China's case, the District Energy Bureau in collaboration with the Biogas Association served as the coordinator for collection of biogas digester data. The sample size should cover one percent of the overall sampling size to give a standard error of five percent.

Table 11: Small scale CDM biogas project

Project	India	China	Nepal
Livestock per HH	4 cows	3 pigs	4 cows
Digester number	5,500	10,000	162,000
Digester size	2 m ³	8 m ³	4-10 m ³
kW/digester	1.81		
CER/digester/yr	4.93	1.797	7.76 for Terai 5.38 for Hills 5.48 for Mountain Average = 4.6
CER(tCO ₂ e/yr)	27,111	17,967	530,000
Cumulative CERs	189,905	179,670	5.3 MtCO ₂ e for 10 years
1. Baseline	<ul style="list-style-type: none"> - Replace firewood from non-sustainable sources - Replace inefficient wood stove - Replace 46 l/yr/HH kerosene with biogas 	<ul style="list-style-type: none"> - Replacement of firewood from non-sustainable sources - Replace inefficient wood stove with biogas - Replace kerosene 	<ul style="list-style-type: none"> - Replace firewood from non-sustainable sources - Replace kerosene with biogas - Claim N₂O offset from replacement of inorganic fertilizer - Claim fugitive CH₄ and N₂O emission from manure left or stored in the field
2. Monitoring plan	<ul style="list-style-type: none"> - Rely on support service contractor to monitor on the number of digester installed and in operation 	<ul style="list-style-type: none"> - Rely on Provincial Energy Bureau to carry monitoring along with Village Biogas Association 	<ul style="list-style-type: none"> - Rely on contractor to monitor installed and operational digester
3. Issues	<ul style="list-style-type: none"> - High transaction cost - Inflexible Bundling 	<ul style="list-style-type: none"> - Ownership of CERs - Upfront capital 	<ul style="list-style-type: none"> - Definition of non-sustainable forestry - Sustainability of Government subsidy

Source: Jason Yapp, 2005.

4.4 Limitations of CDM as Financing Instruments²¹

The potential of CDM financing for domestic biogas has been significantly reduced following the decision of the Executive Board (EB) in November 2005 to remove the small-scale CDM methodologies from the reference to projects that replace non-renewable biomass. This was done to avoid double accounting of carbon stocks and carbon pools and the difficulty in proving that the biomass used is non-renewable. The CDM projects affected by this decision are all small-scale renewable energy programmes aimed at providing access to sustainable energy for households.

The Executive Board requested submissions by 5 December 2005 of alternative methods for calculating emission reductions for small-scale project activities that propose the switch from nonrenewable to renewable biomass, while not accounting for any net increase of carbon pools compared with what would occur in the absence of the project's activity.

As of October 2005, 26 PDDs relating to biogas on large-scale pig farms in Latin America (Brazil, Mexico, Chile) had been submitted for validation along with seven PDDs related to medium-scale pig and dairy farms (Philippines, Mexico) and one PDD relating to 5,500 domestic biogas plants fed by cattle dung (India). More recently, two PDDs relating to domestic biogas in Nepal were validated and registered by the Executive Board of CDM on 27 December 2005. For small-scale biogas programmes, a high transaction cost remains a barrier as the inflexible bundling rules will make the CDM project unattractive to potential investors. At the International Seminar on Biogas Technology in Beijing in 2005, Dr. Jason Yapp concluded that once the barriers and risks are properly identified, carbon finance could provide a real opportunity for reinvigorating the uptake and commercialization of biogas systems. He recommended exploring the feasibility of developing CDM projects based on sector-oriented policies in order to reduce the transaction costs, addressing additionality test issues as well.

For the past several years, renewed efforts have been undertaken for the scaling-up and market development of domestic biogas projects in Asia, especially in China, Nepal, Viet Nam and India. It is most unfortunate that the reference to projects that replace non-renewable biomass has been removed from the small-scale CDM methodologies. Hopefully, alternative methods for calculating emission reductions for small-scale project activities that propose the switch from non-renewable to renewable biomass will become available soon, as this will increase the potential of CDM to speed up the commercial development of domestic biogas.

5. Strategies for Biogas Development

5.1 Involvement of the Private Sector

Biogas Programme in Nepal²²

The Nepal biogas programme has been implemented with the involvement of various actors. Among them, the private sector plays a crucial role. Actors from the private sector are: (a) biogas companies; (b) appliance manufacturers; and (c) financing institutes.

A. Biogas Companies

Before the start of Biogas Support Program(BSP), there was only one company that was established, with the initiation of Agriculture Development Bank of Nepal. Once BSP was established, it adopted an approach of opening opportunities for private biogas companies to participate in the programme. The aim of involving more private biogas companies was to increase the number of plant installations through open-market competition and commercialization of the biogas sector. The number of biogas companies increased gradually every year and reached 62 in 2005.

Biogas plants are constructed by the recognized biogas companies as per the specification and fixed standards approved by BSP. These companies also provide after-sales services and repair and maintenance training to the users. Quality control of the installed biogas plants is done by BSP. It is striking to note that as many as 97 percent of the installed plants are in operation, mainly due to enforcement of the quality standard.

The market share of the plants was monopolized by GGC before the establishment of BSP. However, over the years the trend has seen a transition of the market into the hands of the private sector. BSP recognized only one company in the first two years (1992-1993 and 1993-1994). However, it allowed other companies to construct biogas plants outside the programme.

The strength of the companies here is categorized according to their capacity to install a certain number of plants per annum. Those installing only 100 plants are classified as weak, installing between 100-500 plants is medium, and more than 500 plants is considered strong. Biogas companies are also graded from A (excellent) to E (poor) based on their performance every year. The grading system is a strong tool of marketing the biogas plants to potential customers, and forces the companies to maintain high-quality services.

BSP not only approves the companies and controls the activities executed by them, but also assists and advises them through continuous training, business counselling and offers advice on entrepreneurial skills development. BSP believes that once biogas companies are strong enough to supply high-quality products and services, equipped with a strong management and marketing

Strategies for Biogas Development

system, they can continue the biogas construction and the sector can be developed as a commercially-viable and market-oriented industry. The current construction capacity of biogas companies is about 30,000 plants per year. Besides the construction of biogas plants, biogas companies also provide after-sales services, training to the users on operation and maintenance and training on maximum-utilization of bio-slurry as fertiliser.

B. Appliances manufacturers

Biogas plants need appliances such as a stove, dung mixer, gas tap, water-draining device, main gas pipe, gas valve and lamp. Before the start of BSP there was only one workshop that was producing most of these appliances. BSP supported the establishment of other capable private manufacturers to produce quality appliances as per the standards approved by BSP. Currently, 15 such manufacturers are in operation. BSP regularly checks the quality of these appliances produced by recognized manufacturers and looks for continuous improvement through research and development. These manufacturers have the capacity to supply all required appliances except the main gas valve.

C. Financing institutes

One of the most important features of the BSP has been its innovative financial engineering and judicious application of consumer subsidies to help develop the market for biogas plants. Working with the Agriculture Development Bank of Nepal and the Rastriya Banijya Bank (RBB), both Nepalese government banks, a loan and subsidy programme was structured that targeted small- and medium-scale rural farmers. This loan and subsidy programme has been a very critical element in developing the commercial market for biogas plants in Nepal. The subsidy, fixed at three levels (for the Terai, Hill and Remote Hill District) at present, represents 30 percent (on average) of the total cost of the biogas plant. As the amount of subsidy is fixed, its relative contribution to the total price of the biogas plant is expected to decline with rising inflation in the economy of Nepal.

Besides these two government banks, more recently, BSP is working with more than 140 Micro Finance Institutes (MFIs) for biogas lending. These MFIs, mostly cooperatives located in rural areas, lend biogas credit to their members in an easy and transparent way. MFIs do not only provide credit but also disseminate the biogas technology and identify demand for biogas plants to be constructed.

D. Strength of the private sector

An operating principle of BSP has been to strengthen the local capacity and collaborate with the private sector to implement and achieve its objectives. As a result, the BSP technically- and financially-supported the creation and certification of a number of private biogas companies. Clear procedures for contracting, installation, quality control, service, repair and maintenance were developed and followed. This has resulted in the significant growth of a number of companies and biogas plant installations.

The certified biogas companies also provide after-sales service to the biogas plants. They provide each customer with maintenance/service over a three-year period at no cost. In case the constructed plant has any problems, the biogas company will also repair the plant free of cost

during this guaranteed period. This system has ensured that the plant is functioning, and farmers are spared some of the bigger risks associated with investments in biogas plants.

The private sector is encouraged to engage local labors in biogas construction, supervision, credit lending and promotion. Utilization of local persons is relatively cheap, but also effective in demand-creation and after-sales service. With this approach, a significant number of persons throughout the country are knowledgeable on biogas technology. Approximately 11,000 persons are directly employed in the biogas sector. This includes the staff from the biogas companies, appliance manufacturers, materials suppliers and financial institutions. Besides this figure, about 400 new technicians, mostly masons, are trained each year. The development of technicians on the local level not only provides employment opportunities, but also ensures services on biogas plant and promotes the technology more effectively and efficiently in that area. The involvement of the private sector has led to a considerable number of local employment opportunities.

BSP has played a key role in developing and strengthening the technical and institutional capacity of all the important partners associated with the biogas sector in Nepal. Training programmes conducted by the BSP have been critical in establishing and strengthening the capacity of, among others, biogas companies, lending banks, NGOs, biogas inspectors, and even biogas end-users. Thus, the private sector involvement has created an environment to strengthen the capacity of biogas development at the local level.

Biogas consumers are the rural farmers who must be first convinced of the value of owning a biogas plant followed by involvement in the contracting, financing, construction and daily operation and maintenance. They have to be fully informed, trained and supportive of owning, operating and maintaining biogas systems. In this regard, the biogas companies and financing institutions play a major role in motivating and convincing them .

With the establishment and involvement of the private appliances manufacturers, Nepal has become self-sustaining in the production of quality appliances. All of the required appliances, except the main gas valve, are produced in Nepal. The quality of these appliances are centrally controlled so that plant functioning is guaranteed without appliance failure.

The BSP has also encouraged the involvement of local NGOs and international NGOs in the promotion of biogas in Nepal. These NGOs are mainly involved in providing information on biogas, identifying demand for biogas plants and bridging relations between biogas companies and biogas users. Plausibly owing to the involvement of these NGOs in promotional and extension activities, biogas production has increased to some extent. They have established network relations with the local organizations that have good connections with potential biogas households. Similarly, they always look for new strategies for market development and always try to maximize the number of clients.

The private sector has made significant investments in biogas, not only in terms of capital, but also in human resources and other logistic arrangements. They have created a market and a good image within their area of operation. They are motivated to continue in the biogas programme even after termination of subsidies. The new initiative of carbon financing can be an attractive financing source for the continuity of the programme. Carbon financing will only be possible with

Strategies for Biogas Development

the high-quality services of biogas companies. Therefore, private sector involvement ensures the continuity of the programme in the future.

Due to the high number of companies involved in biogas construction, a competitive environment on quality, service and price has been created. It has helped to maintain the biogas installation price and maintain quality service.

The service delivery cost of biogas companies is also relatively lower than that of a government-implemented programme because of competitiveness and utilization of local resources.

One of the objectives of BSP is to develop the biogas sector as a commercial and market-oriented industry that can only be promoted by the involvement of the private sector. In this regard, an umbrella organization of private biogas companies called Nepal Biogas Promotion Group (NBPG) was established to coordinate and support its member companies with capacity building, marketing, appliances supplying and by creating healthy work environments among the companies. The NBPG is bringing biogas companies under one umbrella with collective thinking on sectoral growth and advising the Government for policy formulation and tax exemptions on biogas appliances.

E. Weakness of the private sector

Although the private sector has played a crucial role in wide-scale promotion of biogas in Nepal, there are still some weakness on the part of the private sector.

Private biogas companies expanded from one dominant company to the present level of 62 companies. Of these 62 companies, only eight are presently capable of producing more than 500 biogas plants per year. Many of the companies are financially weak. They require additional management and training support to become "significant players" that are capable of producing more than 500 biogas plants per year. More efficient biogas companies are needed in order to achieve the target of 200,000 biogas plants by mid-2009. To achieve this, they need more support and more supervision from the BSP.

Most of the companies do not have long-term business plans and do not have trans-sectoral thinking. It is risky to depend on such companies for quality services. These short-sighted companies may distort the market with unhealthy competition. Their activities have to be monitored constantly and strict regulations will be required, which will increase the time and resources for the programme.

Since the private sector is free to choose their business and locations, areas where profit is high and the market is big and easy to operate are preferred. If the biogas programme intends to work in remote areas and reach relatively poor people, it is difficult to direct them to work in those areas unless additional support is provided. Therefore, the biogas programme has to focus more to create a better working environment in remote areas with proper promotion, networking and perhaps with higher subsidies made available to remote rural farmers.

Since biogas construction is a seasonal business, most of the companies face the problem of

utilizing their staff throughout the year. This makes it difficult to retain experienced staff throughout the year. A shortage of staff, especially masons, during the construction phase is often an economic problem associated with the personnel management of biogas companies. Most of the companies are more employment-oriented than profit-oriented.

5.2 Involvement of the Public Sector

Biogas Programme in China ²³

Since 2003, biogas construction in rural areas has been included in the programmes financed by the Chinese government bonds. In three consecutive years from 2003-2006, capital financed by government bonds worth one billion CNY, has been invested in household-used biogas construction in rural areas. During the 3-year period, the central government has invested 3 billion CNY (US\$375 million) for biogas construction and for demonstration programmes, covering 1,946 counties with more than 3.1 million rural households benefiting.

For programme dissemination, the government-bond funded programmes for biogas construction in rural areas should include support western China development and should be combined with the policy of "grain for green". Such programmes should be arranged in central and western regions, particularly in western China. The regions for "grain for green", as long as the conditions for biogas construction are available, should be considered first for such programmes. Investments from the central Government in the form of government bonds in biogas programmes for western regions accounts for 55.98 percent, 56.96 percent, and 55.37 percent of total investment in 2003, 2004, and 2005, respectively. The standards of capital subsidies from the central Government are different considering the levels of regional economic development, costs for digester construction, abilities for self-financing. Each household in northeastern and western regions can get subsidies of 1,200 CNY (USD 150), 1,000 CNY (USD 125) in the central region, and 800 CNY (USD 100) in the eastern region.

Years of endeavours have created the consummate organizational and managerial systems from central government down to local departments. These systems are very instrumental for coordinating the links between the programme application, plan assignment, organization and implementation, supervision and examination, compilation and acceptance. In implementation of the programmes, it is up to the Ministry of Agriculture to offer guidelines for programme applications and it is up to the provincial authorities on rural energy resources for organizing county-level rural energy authorities. Then, based on considerable field investigations, the specific counties, villages, and farmers for the concerned programmes will be determined. Lastly, the provincial authorities will complete all of the reports on programme feasibility collectively and submit them to the Ministry of Agriculture for final approval.

Years of experience show that biogas construction in rural areas is not just about solving the energy shortage, but also to promote the protection of ecological environment, increasing farmers' incomes, and raising their quality of life. The "Ecological Homeland" and "Plan to Enrich People" were created to promote biogas construction as organically combined with improving

farmers' production and living conditions, protecting ecological environment, and increasing the farmer's income, until these economic, social, and environmental benefits have been attained. This case is mainly targeted at a demonstration village involved in the Ecological Homeland and Plan to Enrich People at Shipai Village, Jianshi County, Hubei Province aimed at the comprehensive benefits from the biogas development in China.

5.3 Netherlands Development Agency (SNV) Biogas Programmes in Asia²⁴

Based on the successful results in Nepal and encouraging signs from Viet Nam (see below), the Board of Directors of SNV decided to launch an initiative for increasing the biogas market in Asia.

The main objective of SNV's biogas activities is to support the long-term development of sustainable national programmes for the promotion of domestic biogas in a number of developing countries. An initial screening of countries is made on the basis of pre-conditions for large-scale dissemination of biogas plants. If the major pre-conditions are met, SNV undertakes fact-finding missions and feasibility studies in order to make a well-founded "go-no go" decision for intervention. These missions and studies include comprehensive context and multi-stakeholder analyses. In the case of a "go" decision, a detailed proposal for a national programme, including output targets, estimated expenditures and proposed financing, is formulated in cooperation with the different (potential) partners. SNV aims to involve the maximum capacities of organizations and institutions already available in the country and to strengthen these capacities rather than keep the implementation of activities in its own hands.

National programmes require multiple actors to conduct distinguished functions in a co-ordinated manner (see figure 2). SNV aims to support the development of the biogas sector as a whole, and therefore, all actors in the sector are potential partners. The focus of support might shift, depending on the needs of the programme and the capacity of the involved organizations at a certain moment in time. In the end, SNV hopes to see a fully-developed sector in which livestock farmers purchase biogas plants and acquire micro-credit to finance the installation of biogas plants on a commercial basis. Producers of biogas plants and credit institutions compete with each other on a level playing field with an agreed set of quality standards.

With the Asia Biogas Programme, SNV aims to reach about 210,000 households through the installation of the same number of biogas plants, covering about 1.3 million people, in selected countries in Asia.

Several potential problems need to be avoided, however, if the programme is to be a success. These have been identified as: the potential lack of product reliability (quality management); lack of appropriate credit facilities; lack of willingness among suppliers to co-operate and to compete; lack of organizational sustainability; lack of financial sustainability; unsuitability of CDM for national biogas programmes; and decreasing availability of animal dung.

Viet Nam

The market potential for domestic biogas in Viet Nam is large. The country's animal husbandry sector is vibrant, expanding and, for the large part, managed in family farms. Both farmers and the government are keen to reduce the environmental load of the sector and embrace solutions such as biogas plants. Alternatives to inefficient conventional domestic fuel sources are welcomed, as are opportunities to improve the nutrient management of the fields. Out of the technical potential of two million installations, an active demand of one million domestic biogas plants seems a realistic estimate.

In January 2003, the Vietnamese and Netherlands governments signed a Memorandum of Understanding (MoU) for the implementation of the Biogas Project (BP), a domestic biogas dissemination project in ten of Viet Nam's 64 provinces. This project combines Viet Nam's technical knowledge on plant design and construction with SNV's experience with large-scale dissemination of domestic biogas. The Netherlands' Directorate General for International Co-operation is supporting the project financially with an initial grant of US\$ 2 million. The combination has thus far proven successful – at an early stage the project has expanded into two additional provinces and increased its goal from an initial 10,000 to 12,000 biogas plants. In July 2005, six months ahead of schedule, the project reached this goal. In anticipation of a second phase, the Netherlands has agreed to increase its grant to fund an additional 6,000 installations, bringing the project target to 18,000 biogas plants by the end of January 2006.

Encouraged by these results, the Vietnamese Department of Agriculture at the Ministry of Agriculture and Rural Development and SNV agreed on the joint development of a second nationwide phase for the biogas programme. This second phase aims to support construction of 180,000 domestic biogas plants in 58 provinces of Viet Nam over a period of five years. The programme plans to start in February 2006, allowing a smooth transition from Phase One.

The second phase of the programme seeks to ignite a lasting market and consumer demand for domestic biogas plants and to encourage high-quality services to meet this demand. Some of its key components will include:

- Building on past successes and lessons;
- Creating a commercially-viable sector;
- Jump-starting provinces: Over a period, the programme will assist provinces to establish the full infrastructure necessary to support a market-oriented biogas sector;
- Decentralized biogas-training centres – the programme intends to support the establishment of three biogas training centres over the country;
- Maximization of biogas benefits: BP II will put a renewed emphasis on the varied benefits of biogas. This will be accomplished by continuing research into slurry use, targeting disadvantaged households, improving stoves and other related technology, promoting the intangible (social) benefits, and assessing the impact of biogas on women's lives and building on the benefits;
- Innovative financing mechanisms.

The total investment available for the programme is around • 66 million. The proposed financing scheme includes private investment contributions by the beneficiary, investment credit and

Strategies for Biogas Development

investment subsidies, development and government loans combined with CDM revenue, and an ODA grant.

Bangladesh

So far, the Bangladesh Council of Scientific and Industrial Research (BCSIR) and the Local Government Engineering Department (LGED) have been the main actors in the dissemination of biogas plants. In total, close to 24,000 domestic biogas plants of different designs have been installed throughout the country. The fixed-dome model has become the most popular design. However, due to the expiration of projects, the installation of biogas plants has come to an almost complete standstill since June 2004. Only Grameen Shakti continued to install biogas plants, building around 100 in 2005.

In March 2005, SNV conducted a study into the feasibility of a national programme for domestic biogas in Bangladesh. It concluded that such a programme would be feasible as Bangladesh has already a rich history of domestic biogas and has the necessary organizational and institutional capacities. In addition, the technical potential is at least one million units and the financial analysis of an average plant is positive. As the actual price of non-renewable biomass replaced by biogas varies greatly, an effective micro-credit facility will be required. Finally, there is a clear interest among potential stakeholders to be engaged in a national biogas programme.

In July 2005, an implementation partner was chosen in close co-operation with all stakeholders – the Infrastructure Development Company Ltd (IDCOL). Under the biogas programme, a total of 36,450 plants are targeted to be installed between 2006 and 2009. Several activities will be implemented to achieve this target. Promotion and subsidy administration will be two of the activities in which BDT 7,000 • 90 will be provided as subsidy.

Similarly, construction of high-quality plants will be ensured by enforcing parameters of quality standards and quality control systems. To ensure proper functioning of the plant, guarantees on plants and maintenance services will be provided for three years and training in operation and maintenance will be provided to each user. To optimize the use of biogas, regular applied research and development activities will be carried out. The staff of the partner organizations will receive this training as well.

Cambodia

Compared with Bangladesh, the history of biogas in Cambodia is rather limited. About 400 low-cost plastic tube digesters have been installed by various organizations such as Cel-Agrid of the University of Tropical Agriculture, the Cambodian Rural Development Team (CRDT) and the FAO-Telefood programme. A recent survey by GERES-Cambodia among 55 biogas farmers in the provinces of Kampong Cham, Takeo and Kandal showed that about half of them (26 systems) were not in operation. The average lifetime of a plastic tube digester was found to be only around two years, with proper fencing and roofing being identified as items that could improve the durability of such systems.

In January 2005, a study on the feasibility of a bio-digester support programme in Cambodia was

concluded positively. It was decided to focus first on six of Cambodia's 24 provinces. The technical potential in these six provinces was conservatively estimated to be over 220,000 units. In May 2005, a Memorandum of Understanding was signed between SNV and the Cambodian Ministry of Agriculture, Forestry and Fisheries (MAFF) on technical assistance for a national biogas programme. The target for the number of biogas plants to be constructed between 2006 and 2009 is 17,500. Targeted households are those keeping livestock and producing 20-100 kg of dung per day. In addition, the programme hopes to speed up the development of a commercially-viable and market-oriented biogas sector. Efforts will also be undertaken to launch a biogas credit facility through Tahneakea Phum (Cambodia) Ltd. (TPC), a micro-finance institute specializing in agro-credit, and the bank ACLEDA. The Netherlands Development Finance Company (FMO) is a shareholder of both TPC and ACLEDA Bank and may be willing, if required, to strengthen these institutes through capital or services. A permanent technical training centre will be established at the premises of the Polytechnic Institute Preah Kossamak.

6. Concluding Summary and Recommendations

6.1 Experiences from Leading Countries

China²⁵

A new era has been ushered in for biogas construction in rural areas to lay solid ground for large-scale biogas development in China.

Firstly, biogas technologies are becoming mature and operation methods are advanced. Gradually, mature biogas-construction technologies lead to normative standards for building biogas digesters, and these standards have contributed to advancement of technologies, applicable in diverse regions in China. 'One digester and three transformations' (synchronization of biogas digester construction with transformation of pens, toilets, and kitchens) are considered the basic component of the household biogas construction in rural areas. For regions with good infrastructure conditions, such as the transformation of courtyards, water supply, roads, it is guided in the villages involved by the programmes. Modes of ecological homeland are all linked internally by biogas construction according to local climatic conditions, such as the 'four-in-one' model in the north (the addition of a solar-heated greenhouse to 'one digester and three transformations'), 'pig-biogas-fruit' in the south (addition of orchard construction to 'one digester and three transformations'), 'five assortings' in the northwest (addition of cistern construction to 'one digester and three transformations'), These modes can accommodate China's diverse climatic conditions, and offer the farmers comprehensive benefits from digester construction.

Secondly, the demand for and investment in biogas digesters have expanded in China. Positive effects of biogas construction have been recognized and accepted by the vast rural population and biogas digester construction has become the aspirations of many farmers. It is not surprising that comprehensive utilization of biogas is demanded by farmers to benefit from technological progress. Meanwhile, investment from the Chinese government has been incremental: from several millions of CNY during the 7th five-year economic development plan and the 8th five-year plan to tens of millions of CNY during the 9th five-year plan, to hundreds of millions of CNY during the early 10th five-year plan to billions of CNY. Moreover, an increase in the investment from the local government helps to drive biogas construction forward.

Thirdly, the functions have been extended and the benefits have increased. With the technological progress, utilization of biogas has extended its single function by not only covering the domain of life, but also the domains of production, ecology, and environmental sanitation.

Fourthly, the cause for biogas development has been strengthened and biogas management systems consummated. After years of efforts, the systems for management, promotion, scientific research, quality inspection, and training of biogas utilization in rural areas have been established

Conclusions and Recommendations

by the central Government and delegated to the levels of provinces, municipalities and counties. More than 90 percent of counties now have rural energy management and promotion institutions with more than 30,000 staff. There are also more than 30,000 farm technicians that have obtained national professional certificates qualifying them as a “biogas producer.” The working systems and technical services are improving daily.

Lastly, the pilot demonstration has been transformed into a large-scale popularization and promotion. Previously, biogas construction took place only in a few communities but now there are many communities where biogas construction is in progress. A small-scale pilot demonstration has developed into large-scale, concentrated construction.

Recommendations

The financing channels should be enhanced and expanded

In the past two years, the government has strengthened the efforts to finance biogas construction. Public investment is mainly intended for demonstration efforts and guidance. From a long-term perspective, national promotion of rural household-used biogas on a large scale would require enhancing and widening the financing channel. The principle of focusing on self-financing by farmers with an auxiliary governmental subsidy should be maintained, and rules of market-oriented economy should be followed to attract social capital into the mainstream of investment. Modes of financial services should be innovated by offering micro-credit loans to farmers, adopting the financing mode of collective collateral by farmers' interest subsidies by townships, and repayment by farmers after income is obtained. Market mechanisms should be introduced to collect funds from multiple channels, to actively attract private capitals, domestic and foreign, and industrial and commercial capitals into this cause, and to form multiple investment mechanisms. Meanwhile, international capital (such CDM mechanism) should be introduced into biogas construction in rural areas.

Comprehensive utilization of biogas energy should be stepped forward

It was found from investigations of Shipai Village that most farmers mainly use the biogas digested fluids and residuals in the fields and do not combine them with development of industries with high-added values (such as green food, pollution-free farm produces, etc.), limiting the benefits from being fully demonstrated. The comprehensive utilization of biogas-digested fluids and residuals should be promoted, and rural biogas construction combined with adjustment of agricultural structure. This will result in an increasing number of agricultural benefits by increasing farmers' incomes, as well as the competitiveness of farm produces, in order to fully reap the biogas' economic and comprehensive benefits.

Efforts should be exerted to establish the mechanisms for biogas operation and maintenance

Investigations discovered that biogas technicians and managers in Shipai Village were not satisfactory and that management and services lagged. This is also one of the common problems associated with household-used biogas construction in rural areas of China. In the future, corresponding mechanisms should be innovated further to gradually establish the property-type man-

agement mode of construction, operation, maintenance, and services involved in the 'Ecological Homeland' and 'Plan to Enrich People'. It is recommended that specialists be organized for a special study on rural biogas-concerned grass-root management and service system, in order to propose a practical and viable plan on how to establish town-level, rural energy management and promotion institutions and biogas associations for farmers; as well as how to encourage the biogas manufacturers to carry out diversified technical services. This should be followed by biogas demonstration construction in selected pilot counties to further benefit from useful experiences at a minimum cost.

Normative and industrialized development should be put forward

On the one hand, industrial laws should be revised by the government to lift the threshold for products to enter the market, preventing low-quality or copycat products from entering the market. On the other hand, self-discipline should be strengthened in this biogas industry. Intellectual property rights should be protected and the procurement of auxiliary equipments and main raw materials used for rural biogas construction should be carried out via public bidding. Orderly competition should be encouraged and the enterprises and products that violate regulations should be excluded from the governmental procurement bidding to ensure the continuous increase of technological levels in this industry. Meanwhile, co-operation between enterprises and research institutes should be encouraged to make the best use of technologies and human resources and to strengthen research & development and promotion of new technologies and new products, raising the technological levels in relevant industries in a sustained manner. In addition, promotion of the industrialization of biogas industry necessitates the inclusion of biogas manufacturers for collective product and market exploitation to gradually establish the property-type management system for rural biogas-concerned construction, operation, and after-sale maintenance and services.

Nepal²⁶

There are several key lessons that can be learned from Nepal's biogas programme. These include:

- Adapting the product to the needs and concerns of the end-user and market. Important feedback from the users and their neighbours was obtained through periodic quality checks and surveys used to assess impacts and to improve products and services;
- Establishing and enforcing design, quality and service criteria to ensure the reliability and cost-effective operation of installed systems. A tight relationship was maintained between the disbursement of subsidies and the required standards for the biogas systems;
- Ensuring quality control on all aspects of the production and delivery cycle; and
- Identifying the key institutional partners and strengthening the capacity of these players to effectively carry out their respective roles.

6.2 Socio-Cultural Aspects of Biogas Projects

Participation²⁷

The basic principle of any planning indicates that it would be desirable to involve those concerned in the planning process as early as possible. This principle applies even more if the pre-feasibility studies have revealed a considerable amount of problems. In any case, it is better to discuss these quite openly with those concerned and seek solutions.

The point when full participation should commence is difficult to determine. It is too early to expect full participation before the technology has reached a certain technical maturity and the conditions for its dissemination are fully explored. On the other hand, it is just as wrong to confront people with “final solutions”. In this case there is the risk of obtaining verbal agreement without effective consequence. The ideal time for introducing concept and technology is during the last phase of the investigation, when preliminary results can be shown to those concerned as a basis for discussion. These discussions serve as a first-test of the preliminary results. Furthermore, the structures of leadership and decision-making can be observed clearly in such situations.

That does not mean that each of the proposals by the community should be accepted blindly. The fact that biogas technology requires a specific technical and economical organization should be stressed. A breakdown of planning would be preferable to unfeasible compromises. In view of this, it is often advisable to invite the local technician to take part in these negotiations. Discussions centering on technical aspects tend to be well accepted in situations of disagreement.

A. Religious and social taboos

Taboos, as a rule, are always indicative of an overall social character. The violation of taboos will result in sanctions, the extent and form of which will be determined socially. Sanctions can vary (corporal punishment, exile from the village, etc.) despite the fact that state legislation claims a monopoly for punishment. This does not simplify the problem but makes it even more difficult. Instead of an official, foreseeable punishment, social exclusion occurs in many cases and can lead to big problems if key players or authorities find themselves denied access to the project. As “social punishment” is forbidden, the “sanctions” are not spoken about, especially when they target a programme desired and aided by the state. An exclusion of participants by the community with all its negative consequences is not declared as such by the community and, therefore, rarely directly accessible.

On the other hand, from these “sanctions” arises the opportunity to overcome resentments. In general, sanctions are governed by a “ruling entity” or “authority” who watches over these taboos and proclaims the punishment when they are violated. But this authority also determines possible exceptions. A general misconception is that taboos “cannot be broken”. No society is inflexible to the extent that regulations do not allow for changes and modifications. Of course, exceptions have to be agreed upon by a recognized entity.

B. Social classes and class barriers

In their general features, social classes are the binding structure in each society and an important phenomenon which has to be reckoned with and included early enough in planning. It must be taken into account that class structures and class barriers exist in locally specific variations which have a considerable influence on the implementation of a biogas digester.

C. Definition of position of the target group

Equally important to the development of question and control structures is the definition of the position of the target group in relation to its neighbouring groups. The extensive observation of the whole society can provide a series of criteria for the initial analysis. Special importance is attached to this method in the following situations:

- The proposed group or institution is not or is only minimally self-sufficient in its biogas measures. It requires deliveries (material or service) from other groups, either a neighbouring village or another enterprise. Such matters become relevant whenever certain regulations exist within the extensive class system but do not appear within the local system. In such cases, an investigation has to take place, for example, whether neighbouring groups who would have to deliver substrate would accept this. This investigation is of great importance within the target group because a “violation” of the class system is accepted. It is frequently found out afterwards that this “violation” is not given because the essential suppliers do not accept their counterparts; now and again it can be seen that certain groups within the target group only give their approval because they are sure that the conditions negotiated would not be accepted by the partner groups.
- The implementation takes place within the context of a more extensive programme, possibly a pilot programme. In this case it is not sufficient to obtain the acceptance; only within the temporary target group would an investigation into whether this model is acceptable for later target groups be carried out. Although it is in principle practical to keep the model variable for later adaptation to other target groups, it should not be overlooked that the interest of later target groups will be affected by the pilot model. Violations of social norms which are acceptable for the initial target group could be rejected in neighbouring communities and lead to a general rejection of the biogas project. Consequently, pilot models should avoid “far-reaching” violations, even if these are locally possible.

D. Social regulations for the division of labour

Social regulations for the division of labour can arise for the following reasons:

- Privileges of certain groups in taking over specific jobs or being released from less desirable work. These privileges can stem from belonging to a certain social or ethnic group, age group or sex;
- Social and traditional allocation of specific work for specific groups. The division of labour among the sexes belongs here;
- “Regulations” on the division of labor caused by political or economic dependency, which means, for example, the necessity for the “village rich” to carry out certain tasks in order to secure labour during the busy seasons of agricultural activities.

Conclusions and Recommendations

The regulations on the division of labour always prove to be an especially persistent phenomenon; “leading” groupings frequently refuse to carry out socially or religiously “banned” jobs (handling faeces, heavy manual work, etc.) as they are “non-rank conforming” and force socially or economically dependent groups to take over these tasks. This applies especially to the division of labour between sexes.

Gender Considerations²⁸

Women are kept out of many decision-making processes even though they are usually the primarily affected group regarding household energy issues. Their participation can, for instance, be encouraged by integration into authoritative bodies or by forming special female committees.

Participation Mode

What form of participation is appropriate for women cannot be decided from the outside. It is of little use to the women if they are “forced” into a decision-making body without being truly accepted by other members. Their impact could be even less than by influencing of the husband. When there are problems with the plant, it is the women who can be a stabilizing element. As they are more affected by malfunctioning of the plant, they are more interested than men in, for example, a well-functioning repair service.

Different models according to the standing of women in society

- The careful integration of women into decision-making bodies;
- Women committees for the regulation of consumer problems whilst matters of finance are left to the men committees;
- Specialized committees with a gender-balanced central body.

6.3 Political and Administrative Considerations²⁹

Political Will and Public Opinion

The development of biogas technology depends on the political will of the donor and the recipient governments. It is the task of the Government and administrative authorities to provide access to the technology and to secure and organize the requisite materials, financial resources and legal basis. According to their political will to promote biogas, governments can play a more or less supportive role in biogas research, information dissemination and the regulations for funding, subsidies or tax-waiving. The formation of a political will does not evolve in a vacuum. Political will and public opinion are inter-related. Successful practical examples, encouraging research findings, and the use of media to spread information are all tools to influence both political will and public opinion.

Biogas programmes should attempt to lobby for biogas at various entry points of the government system simultaneously. Creating a favourable climate for biogas dissemination depends almost always on a whole range of decision makers. For example:

- The Ministry of Finance will decide on subsidies and tax exemption for biogas users;

- The Ministry of Energy can propose laws regarding the feeding of biogas-produced electricity into the grid. It can also propose financial and other assistance;
- The Ministry of Agriculture and Livestock can include biogas in the training curriculum of extension officers and agricultural colleges;
- The Ministry of Education can include biogas in the curriculum of high schools and promote the construction of bio-latrines for schools;
- The Ministry of Health can include biogas in the curriculum of public health workers and encourage the building of bio-latrines for hospitals.

Besides political lobbying, public relations work is also important to influence public opinion. For example:

- Radio programmes are an effective means in rural areas to familiarize the population with basics of biogas technology;
- Articles in print media usually reach members of the middle class, among whom are the most promising potential users: middle- to large-scale farmers;
- Pilot biogas systems must be located strategically to be easily accessible. The more these pilot plants have a "real life character", i.e., be an operational part of a farm, the more convincing they will be for other farmers;
- Visits to Agricultural Schools and Colleges do not reach the decision-makers of today, but lays the ground for biogas acceptance in the future.

Programme Goals

Since the actual installation of a biogas plant is ultimately the decision of the individual investor, it is important that the programme goals and the organizational environment are conducive to affirmative decisions of the individual. The prerequisites for this must be established at all planning stages by and for all sectors concerned. A biogas programme which is part of a larger development programme, must harmonize with that of the other departments of the parent programme. The introduction of biogas as an alternative source of energy affects various sectors, each of which functions within its own specific structural setting. These, of course, vary from one country to another. As a rule, the responsibilities within a biogas programme should be distributed along the lines of existing contacts with the corresponding target groups. If, for example, certain farmers are considered the target group of an information campaign, it would be appropriate to have the Ministry of Agriculture involved in the biogas programme.

Administration

No new administrative bodies should be established for performing the above tasks. Instead, it is advisable to set up biogas promotion units or biogas contact persons within the existing departments and agencies. Within the framework of a well-established development programme, particular importance should be attached to self-help groups, voluntary agencies and/or private foundations.

The authorities' efforts in favour of biogas promotion will be more effective, if sufficiently detailed information is placed in the hands of the self-help groups. The concerned administrative bodies must disseminate the requisite information and provide inexperienced groups with a satisfactory explanation of how to best exploit the promotional options available to them.

Conclusions and Recommendations

Practical assistance should be offered wherever possible. Proactive self-help groups will then become ideal multipliers.

ENDNOTES

- ¹ Information Advisory Service on Appropriate Technology, German Agency for Technical Cooperation, "Biogas Basics", 2005. <http://www.gtz.de/de/dokumente/en-biogas-volume1.pdf>.
- ² Ibid.
- ³ Ibid.
- ⁴ Ibid.
- ⁵ Ibid.
- ⁶ Van Nes, W. J., Asia hit the gas, Renewable Energy World, 2006.
- ⁷ Wang, Mengjie, Biogas Technology And Ecological Environment Development In Rural Areas Of China, Chinese Academy of Agriculture Engineering Research, 2002. http://www.ecosanres.org/PDF_files/Nanning_PDFs/Eng/Wang_Mengjie_12_C19.pdf.
- ⁸ Ibid.
- ⁹ The Canadian Agricultural Energy End Use Data and Analysis Centre (CAEEDAC), "The Economics of Biogas in the Hog Industry", 1999.
- ¹⁰ Reddy, Amulya et al., Community Biogas Plants Supply Rural Energy and Water: The Pura Village Case Study, UNDP – Energy as an Instrument of Socio-economic Development, 1995. http://www.undp.org/seed/energy/policy/ch_8.htm.
- ¹¹ Ibid # 7.
- ¹² Raninger, Bernhard et al., "Activities to Apply the European Experience of Anaerobic digestion of Bioorganic Municipal Waste from Source Separation in China – The Sino-German RRY-BMW Project in Shenyang, 2005.
- ¹³ Vasudeo, G., Biogas Manure (BgM): a viable input in sustainable agriculture – an integrated approach, 2005.
- ¹⁴ Yapp, Jason, "CDM Potential for the Commercialization of the Integrated Biogas System", 2005.
- ¹⁵ Ibid.
- ¹⁶ Ibid.
- ¹⁷ Ibid.
- ¹⁸ Ibid.
- ¹⁹ Ibid.
- ²⁰ Report of the Conference of the Parties on Its Seventh Session, Held at Marrakesh from 29 October to 10 November 2001, http://unfccc.int/resource/docs/cop7/l_3a02.pdf.
- ²¹ Ibid # 6.
- ²² Bajgain, S. and C. Kellner, "The strengths and weaknesses of private sector in the Biogas Support Programme in Nepal, 2004.
- ²³ Center of Energy and Environmental Protection (CEEP), "Analysis of the comprehensive benefits of household-used biogas construction in rural areas", Ministry of Agriculture, China, 2005.
- ²⁴ Ibid # 6.
- ²⁵ Ibid # 7.
- ²⁶ Ibid # 14.
- ²⁷ Ibid # 1.
- ²⁸ Ibid # 1.
- ²⁹ Ibid # 1.